

# The Power Handbook

A Guide for Test and Measurement Power Applications

## Preface

Those of you familiar with Keysight's previous power supply handbook (application note 90B) will find quite a few changes in this updated version. Whereas the old handbook focused extensively on issues around power supply circuits and design, this handbook focuses more on how to effectively use power supplies and electronic loads to achieve specific application goals. The intent of this handbook is to provide a "one stop shop" for basic information on power related topics, and it incorporates information from many of our application notes. We hope that you find this handbook a useful tool that allows you to get the maximum benefit from our power focused products.

# Table of Contents

Preface .....	1
Table of Contents .....	2
Chapter 1 – Introduction .....	7
History .....	7
Batteries .....	7
Power Supply Evolution .....	7
Chapter 2 – Electric Power Fundamentals .....	10
Proviso .....	10
Work and Power .....	10
Resistance and Resistivity .....	11
Ohm’s Law .....	11
RMS Power .....	12
Real versus Apparent Power .....	13
Power Factor .....	15
AC Power .....	15
AC Power Through a Resistor .....	16
AC Power Through an Inductor .....	17
AC Power Through a Capacitor .....	18
Power Transmission .....	18
Three-Phase Power .....	18
Chapter 3 – DC Power Supplies .....	24
Introduction .....	24
Linear vs. Switching Power Supplies .....	24
Linear Power Supply Operation .....	24
Switching Power Supply Operation .....	26
Common Mode Current Noise .....	27
Summary and Power Supply Trade-Offs .....	29
Keysight’s Ultra-Low Noise Sources .....	30
Output Characteristics .....	31
Operating Quadrants .....	31
Rectangular output characteristic .....	31

Multiple-range output characteristic.....	32
Autoranging output characteristic.....	33
Modes of Operation.....	34
Understanding Ohmic Voltage Drop.....	35
Wire gauge and length.....	35
Eliminating Ohmic voltage drop.....	36
Protection Features .....	37
Over Voltage Protection (OVP) .....	37
Over Current Protection (OCP) .....	38
Combining Supplies in Series and Parallel .....	39
Connecting power supplies in series for more voltage.....	39
Connecting power supplies in parallel for more current.....	40
Measuring Power Supply Output Current .....	41
Using an external ammeter .....	41
Using a DMM with an external current shunt .....	42
Using the DC power supply's built-in capabilities.....	42
Connection Considerations.....	43
Minimizing noise .....	43
Output relay concerns .....	44
Advanced Power Supply Features .....	46
Dynamic waveform measurement.....	46
Generating arbitrary waveforms .....	46
Two Quadrant Power Supplies .....	48
What is a two-quadrant power supply? .....	48
Issues when operating near zero volts .....	48
Regenerative Power Supplies .....	51
What is a regenerative supply?.....	51
Source/Measure Units (SMUs) .....	52
What is an SMU?.....	52
Keysight SMUs.....	52
Chapter 4 – Electronic Loads.....	58
Electronic Load Basics .....	58
What is an electronic load?.....	58

Why use a load rather than a resistor?.....	58
What are some typical E-load applications?.....	59
DC Electronic Load Operation Modes.....	59
Constant Current (CC) Mode.....	59
Constant Voltage (CV) Mode .....	61
Constant Resistance (CR) Mode.....	63
Constant Power (CP) Mode.....	64
Unregulated (UNR) Mode .....	66
The Effect of FETs on Load Behavior.....	67
Overcoming low input limitations.....	68
Zero volt load .....	69
Combining Loads in Parallel .....	69
Never combine electronic loads in series .....	69
Combining loads in parallel to increase current .....	71
Protection Features .....	71
Over-power protection (OPP).....	71
Over-current protection (OCP) .....	71
Under-voltage Inhibit (UVI).....	71
Selecting the Right Electronic Load.....	71
Chapter 5 – Batteries .....	73
Introduction .....	73
Battery Basics.....	73
Overview .....	73
Battery Electrical Ratings .....	75
Battery Profiling and Emulation.....	76
Measuring Battery Resistance versus State-of-Charge.....	82
Standard Battery Test Procedures .....	85
Rated Capacity .....	85
Capacity Retention.....	87
Effective Internal Impedance.....	87
Resistance Test.....	87
Impedance Test.....	87
Discharge Rate Effect on Capacity .....	88

Life Cycle Performance .....	88
Extended Overcharge.....	88
Miscellaneous Tests .....	89
Battery Test Equipment Requirements .....	91
Battery Testing with Electronic Loads.....	93
Chapter 6 – Power Conversion .....	95
Introduction .....	95
DC to DC Conversion .....	95
DC to DC converter testing overview.....	95
Testing DC to DC efficiency .....	96
Testing DC to DC converter load regulation .....	97
Testing DC to DC converter line regulation.....	98
DC to AC Conversion .....	99
Power Inverters.....	99
Power Transistor Testing .....	100
AC to AC Conversion .....	101
Transformer basics.....	101
AC Sources.....	103
Chapter 7 – Photovoltaic Power .....	105
Introduction .....	105
Photovoltaic Cells.....	105
Photovoltaic cell basics .....	105
Modeling solar cell output .....	106
Factors affecting solar cell output .....	108
Ground Testing of Solar Arrays for Satellites.....	110
Why perform ground testing? .....	110
Solar array considerations for satellites .....	110
Solar array simulation .....	113
Can programmable power supplies simulate solar arrays?.....	113
Keysight Solar Array Simulator Solutions.....	114
Creating an Optimal Solution.....	114
Summary and Conclusions .....	116
Chapter 8 – Power Supply Software .....	117

Instrument Control Basics.....	117
Physical Communication Medium .....	117
I/O Protocols .....	118
What is an instrument driver? .....	120
Keysight Command Expert.....	121
What is Command Expert? .....	121
Exporting into other programming environments .....	122
Keysight BenchVue.....	123
Advanced Power Control and Analysis Software.....	124
Power Supply Software.....	126
Glossary – Power Supply & Instrument Control Terminology.....	128
Appendix A – Overview of Keysight Power Solutions.....	136
Basic Power Supplies.....	136
E36100 Series of Basic DC Power Supplies .....	136
E36300 Series of Triple Output Bench Supplies.....	137
N8900 Series of 5, 10 and 15 kW Auto-Ranging DC Supplies .....	138
Advanced Power Supplies.....	139
N6900/N7900 Advanced Power System DC Supplies .....	139
RP7900 Series of Regenerative Power Systems.....	140
Electronic Loads .....	141
N3300 Series Modular DC Electronic Load .....	141
Benchtop Power Analysis.....	142
N6705C DC Power Analyzer .....	142
AC Power Sourcing and Analysis.....	144
AC Sources.....	144
PA2200 IntegraVision Power Analyzers .....	144

## Chapter 1 – Introduction

### History

While it is obviously not essential to understand the history of power supplies to use them, delving a little bit into the history of products can often provide some useful insights into their design and applications. The history presented here is intentionally very brief, but we hope that it helps elucidate some of the reasons that modern power supplies and related instruments evolved into their current forms.

### Batteries

While batteries are obviously not power supplies, they do represent the first examples of devices designed to output current at a stable DC voltage. In addition, it was the desire to replace batteries with an equivalent power source that could run off of household AC power that led to the creation of some of the first DC power supplies. Therefore, any power supply history needs to include at least some discussion of batteries.

There is an ongoing debate as to when people developed the earliest batteries, with some claiming that ancient civilizations constructed crude batteries over two-thousand years ago (the purpose of which is not clear). The famous American Benjamin Franklin first used the word “battery” in 1749 to describe a device he constructed using a set of capacitors. However, the general consensus is that the famous Italian physicist Alessandro Volta created the first modern battery in 1799. His “galvanic cell” consisted of disks of copper and zinc separated from each other using cloth soaked in salted water. Each of these cells was able to supply a constant current at 0.76 V, and you could stack multiple cells together to increase the voltage. Modern batteries use different materials to create cells with voltages that vary from 1 Volt to approximately 3.6 V, and of course you can stack the cells together to create a desired voltage.

A disadvantage of the early batteries was that they were all *primary batteries*, meaning that they were not rechargeable and users had no choice but to discard them once their chemical components reached a state of depletion. The need to replace primary batteries relatively frequently limited their initial applications, since replacing large batteries often is not cost-effective. Therefore, when Gaston Planté invented the first *rechargeable battery* (using lead-acid) in 1859 by it was quite an innovation. The technology of lead-acid batteries has been so robust that they continue to this day to be the power source used to start most internal combustion engines.

### Power Supply Evolution

To understand the development of DC power supplies one has to understand the origins of power transmission. In 1880 Thomas Edison’s company began marketing his incandescent lighting products, which required the creation of an electricity transmission infrastructure. However, the inefficiency of DC power transmission and the different types of loads (lighting, motors and trolley cars) that these systems had to serve limited their expansion. The efficient transmission of power over long distances requires the use of high-voltage AC signals (see Chapter 2 for more information), so the main breakthrough for this technology came in 1881 when Lucien Gaulard and John Dixon Gibbs developed the first early transformer. Transformers allowed for the easy conversion of electricity created at power generating stations into high-voltage AC waveforms that other local transformers could converted down into lower AC voltages for industrial and household applications. In 1888 the first AC motors appeared, although the lack of widely available three-phase power transmission delayed the adoption of more efficient

three-phase AC motors. Therefore, in the 1890's both the technology and the need for AC power transmission systems came together and created a swift expansion of AC power networks.

In the 1920's there was rapid growth in radio technology, and the vacuum tubes used in those radios required rechargeable "B" batteries to operate. Often radio users recharged these batteries using a car, and their lead-acid technology could cause quite a bit of damage in the event of a leak. Also, relying on batteries meant that the radio could die during an important broadcast and that you could damage your radio if you accidentally misconnected the battery after recharging it. Therefore, as more and more homes had AC power available there was a strong demand from consumers for a B battery substitute. As a result, several companies developed AC to DC power supplies for use as B battery alternatives. However, the market for these power supplies dried up around 1929 when most radios began including a built-in power supply.

In the 1930's and 1940's the demand for DC power supplies remained small, with the dominant power supply technology using vacuum tube linear regulators. Since they utilized vacuum tube technology, these power supplies ran very hot (although this was not much of a concern since the tube circuits were virtually impervious to heat). The next major power supply innovations did not come until the 1950's with the invention of the semiconductor-based transistor. While transistors provided many benefits over vacuum tubes, power supply designers had to start paying more attention to efficiency and power dissipation since transistors can easily fail at high temperature. At that time the majority of power supplies were still linear power supplies (see Chapter 3) that require a large bulky transformer and produce a large amount of waste heat.

In the 1960's the requirements of NASA and the aerospace industry for smaller and cooler power supplies boosted demand for a more efficient alternative. While quite a bit more complicated to design, switching power supplies were the obvious solution. Fortunately, the development of improved transformer core materials (lower loss ferrites) and the availability of higher speed transistors with improved switching speeds (which permitted designers to use much smaller components) boosted their development. The 1960's also saw the transition of the electronics world from analog to digital circuitry, which further boosted demand for more accurate and stable DC power supplies.

In the 1970's the energy crisis and the development of the minicomputer and personal computer combined to drive continued demand for smaller and more efficient power supplies. Some early adopters of switching power supplies in the minicomputer industry were Digital Equipment's PDP-11/20 (1969) and Hewlett-Packard's 2100A (1971). However, virtually all of the major electronic companies began employing switching power supplies in the 1970's, and they began to incorporate them into a broad range of equipment including computer terminals, typewriters and desktop calculators. One of the touted innovations of the Apple II computer (released in 1977) was its use of a switching power supply. However, this feature was not really revolutionary as switching mode power supplies were already in wide use by then.

The 1980's saw the expanded use of switching power supplies as their performance improved to the point where their noise characteristics were comparable to those of linear supplies. Of course, over time technology has continued to improve and switching power supplies now dominate the market, with linear power supplies relegated to certain specialized applications.



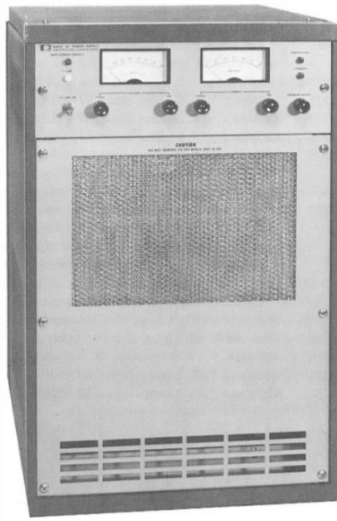

HP SCR-10 Series 10 kW power supply  
circa 1980  
Height = ~16 U (27.75 inches; 705 mm)  
Weight = >500 lbs. (227 kg)



Keysight RP7900 Series 5-20 kW  
regenerative power supply today  
Height = 3 U (5.25 inches; 133 mm)  
Weight = ~70 lbs. (32 kg)

Figure 1.01 – Power supply from the 1980's compared with modern version.

## Chapter 2 – Electric Power Fundamentals

### Proviso

This chapter is optional reading for those of you who would like to have a strong theoretical understanding of power. Reading this chapter is not necessary to move on to chapter 3. If your main interest in this handbook is getting some practical help deciding what power supply or electronic load best fits your needs, then you can safely skip this chapter for now.

If this chapter is optional then you might ask: Why include it at all? The answer is that power is not a simple topic, and it has many aspects not always clearly understood by engineers and technicians not specialized in this field. The following material does help to clarify important concepts and provides background information for the discussions in the subsequent chapters.

### Work and Power

We start with the concept of work. In physics we define work as the action of a force on a particle as the particle moves over a distance as defined by the following vector equation.

$$W = \vec{F} \cdot \vec{d}$$

Note that although we have to know the various vector components of force acting on a particle as it moves through three-dimensional space, the value of work itself is a scalar quantity. We know that an electric field will act on a charge ( $q_0$ ) with a force proportional to the charge and the magnitude of electric field vector component(s) acting on that charge. Moving this charge some distance in the electric field therefore requires work. We can define the *electric potential difference* between two points A and B in an electric field acting on a charge  $q_0$  by the following equation.

$$V_B - V_A = \frac{W_{AB}}{q_0}$$

In electronics we prefer to work with the concept of electrical potential at a point in space. We do this by selecting point A in the above equation to be at a great distance (technically infinity) away from all other charges in our system and by defining the value of  $V_A$  at this infinite distance to be zero. This allows us to simplify the above equation and define the *electric potential* as follows.

$$V = \frac{W}{q_0}$$

In this equation it is understood that the value of  $W$  is the amount of work it takes to move the charge  $q_0$  to the position designated by point B in the electric field.

Understanding the amount of work performed is actually less interesting than understanding the rate at which this work is taking place, which is power. The *average power* delivered by a system is simply the total work done divided by the total time.

$$\bar{P} = \frac{W_{Total}}{t_{Total}}$$

From our previous equations we know that

$$W = V \cdot q$$

It therefore follows that

$$P = \frac{\Delta W}{\Delta t} = V \frac{\Delta q}{\Delta t} = V \cdot I$$

## Resistance and Resistivity

If we applied a voltage across two similarly shaped rods of copper and carbon then we would observe very different resulting currents. The property that enters into play here is *resistance*. We define the resistance between two terminals of a conducting material by applying a potential voltage across those terminals, measuring the current and dividing the voltage by the current:

$$R = \frac{V}{I}$$

The resistance of a particular sample obviously depends on its physical dimensions, so it is often more convenient to refer to the material property of *resistivity*, which is independent of a sample's size. It is easy to calculate the resistivity from a resistance measurement if the cross-sectional area of the sample is known as shown below.

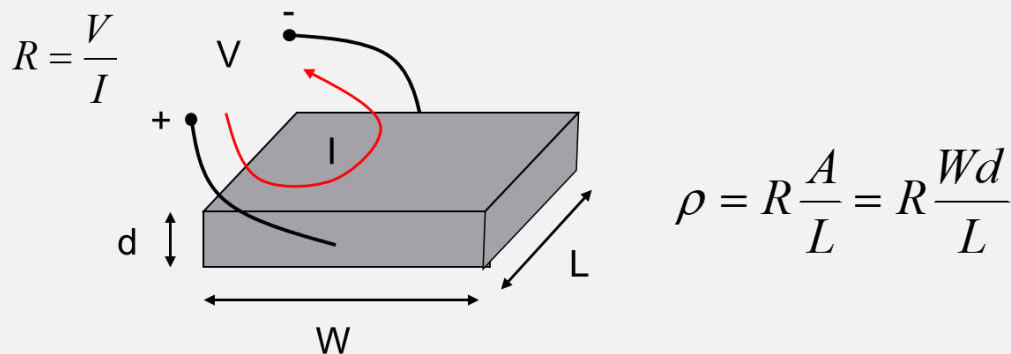

Figure 2.01 – How to calculate resistivity from a resistance measurement.

## Ohm's Law

If we apply a variable voltage across the terminals of many (although not all) material samples and plot the current then we see a straight line. This means that the resistance of the conductor is the same no matter what voltage we apply to measure it. This important result (which holds for all metallic conductors) is known as *Ohm's Law*. However, we do need to note that this result depends upon the sample remaining at a constant temperature as we apply the various different voltages. This is not always easy to accomplish, as applying any voltage (or current) to a resistor generates power that dissipates as heat as the following equations show.

$$P_{Resistor} = V \cdot I = \frac{V^2}{R} = I^2 \cdot R$$

In practice accurately measuring the resistance (or resistivity) of a sample without causing self-heating effects can be a challenging task. This is particularly true for low-resistance materials that require us to apply large voltage or currents in order to obtain a measurable current (or voltage).

## RMS Power

We know how to calculate the power dissipated if we apply a DC voltage to a resistor, but what about the case of a time-varying waveform? If the waveform is periodic then we can still calculate the average power dissipated over time by calculating the power dissipated over one period and dividing by the time it takes to complete one period. An interesting question to ask is: What is the equivalent DC voltage (or current) that we would have to apply to achieve the same amount of power dissipation?

The calculation of this equivalent DC value obviously depends upon the characteristics of the periodic waveform. Fortunately, most of the time in electrical engineering we are dealing with sinusoidal waveforms, which makes the calculation of this value much easier. Suppose we have a voltage waveform defined as follows.

$$V(t) = V_0 \sin(\omega t)$$

To calculate the average power dissipated through a resistor over one period we need to calculate

$$\bar{P} = \left( \frac{V^2}{R} \right)_{\text{One Period}} = \frac{1}{R} \left( \frac{1}{T} \int_0^T V_0^2 \sin^2(\omega t) dt \right)$$

Rearranging and using trigonometric identities we have that

$$\bar{P} = \frac{V_0^2}{RT} \int_0^T \left( \frac{1 - \cos(2\omega t)}{2} \right) dt$$

$$\bar{P} = \frac{V_0^2}{RT} \cdot \left[ \frac{t}{2} - \frac{\sin(2\omega t)}{4\omega} \right]_0^T$$

We can make use of the fact that  $T = 2\pi/\omega$  to arrive at the final result.

$$\bar{P} = \frac{V_0^2}{2R} = \frac{\left( \frac{V_0}{\sqrt{2}} \right)^2}{R}$$

Thus, we can see that in the case of a sinusoidal waveform of amplitude  $V_0$  the value of DC voltage that you need to apply to a resistor to dissipate the same amount of power is:

$$V_{DC \text{ Equivalent}} = \frac{V_0}{\sqrt{2}} \triangleq V_{RMS}$$

This provides us with the convenient result that in the case of sinusoidal waveforms we can compute their equivalent DC value simply by dividing their amplitude by the square root of two. We usually refer to this as the *root-mean-square* value of the waveform and it has the subscript notation “RMS” as indicated in the above equation. It is worth emphasizing that this convenient result works only for sinusoidal waveforms, and for other types of periodic waveforms you would need to integrate them over one period and divide by the period in order to determine their equivalent DC value.

### Real versus Apparent Power

Virtually all practical circuits contain resistive, capacitive and inductive elements in some combination. We also know from basic circuit theory that, of these elements, only the resistive elements dissipate net power. The capacitive and inductive components store energy, but (at least for ideal elements) they do not dissipate that energy and we can recover it from them. However, in order for the circuit to function we need to supply enough power to the circuit to satisfy both the resistive and reactive components. This gets to the essence of understanding what is meant by real versus apparent power.

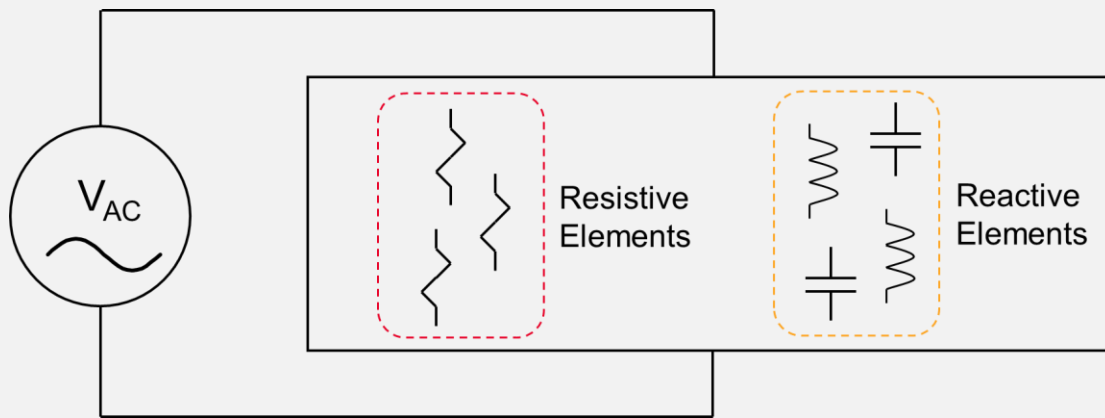

Figure 2.02 – This is a conceptual diagram of a typical circuit with both resistive and reactive elements.

In AC circuits we are applying some sort of sinusoidal stimulus to the circuit, so the voltage and current waveforms are both sinusoidal with constantly varying amplitudes. The total power dissipated is still equal to the product of voltage and current (i.e.  $P = V \times I$ ); however, this value will obviously vary over time. Maximum power dissipation occurs when the voltage and current waveforms completely align with no phase difference, since their peaks and zero crossings are occurring at the same time. Under this condition we state that the voltage and current waveforms are in-phase. Circuit impedance determines the phase relationship between voltage and current, and in general it is a complex quantity. You can view impedance as a triangle in the complex plane, where the resistive component corresponds to the x-axis and the reactive component corresponds to the y-axis.

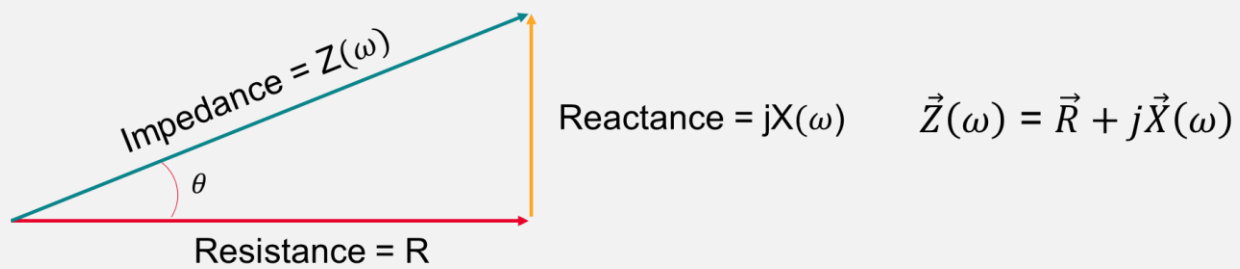

Figure 2.03 – The impedance triangle.

Impedance is a complex number represented as the vector sum of its resistive and reactive components. It has both a magnitude ( $Z$ ) and a phase angle ( $\theta$ ), so we can use basic trigonometry to calculate the relationships between resistance, reactance and total impedance.

$$R = Z \cos \theta$$

$$X = Z \sin \theta$$

Although  $R$  does not depend on frequency the reactive portion of impedance is frequency dependent, so its value (and the value of  $\theta$ ) will vary with frequency.

It is possible to take this impedance triangle and use it to calculate the various components of power using Ohm's law for a DC circuit ( $P = I^2 R$ ). The following table summarizes these quantities.

Term	Equation	Units
Real Power	$P = I^2 R$	Watts (W)
Reactive Power	$Q = I^2 X$	Volt-Amps Reactive (VAR)
Apparent Power	$S = I^2 Z$	Volt-Amps (VA)

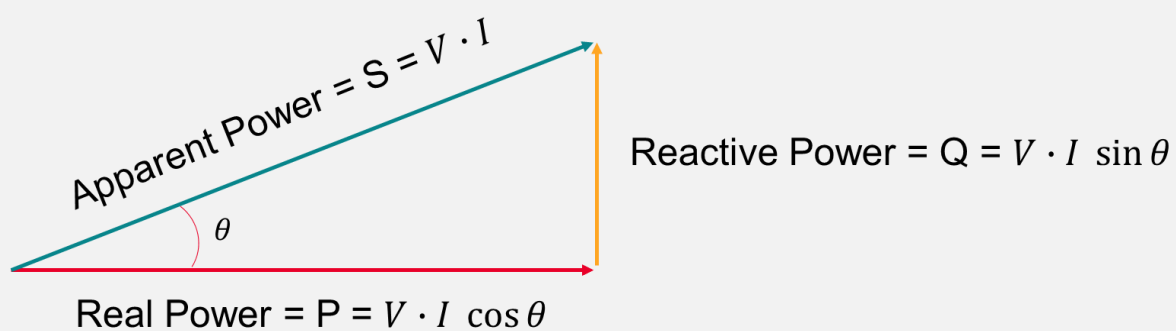

Figure 2.04 – The power triangle.

## Power Factor

Real power (also known as active or true power) is the power consumed by the resistive elements of a circuit and its unit of measure is Watts. The resistive elements do not have any reactive component to them, so all of the power they dissipate converts into heat, light and/or work. An important term to understand is the *power factor*. In mathematical terms the power factor is the ratio of the real power dissipated by a load divided by the apparent power going into that load.

$$\text{Power Factor} = \frac{\text{Real Power}}{\text{Apparent Power}} = \frac{P}{S} = \frac{V \cdot I \cos \theta}{V \cdot I} = \cos \theta$$

Power factor is dimensionless, with values ranging from 1 to -1 (a negative power factor occurs when the circuit or device that is normally the load generates power back to the source). Conceptually, you can think of the power factor as the amount of useful work actually generated from the apparent power applied to a circuit or load.

## AC Power

Let us now examine the case where voltage and current are both sinusoidal waveforms at the same frequency. In the general case we need to consider the effect of a phase difference, theta, between these two waveforms as shown below.

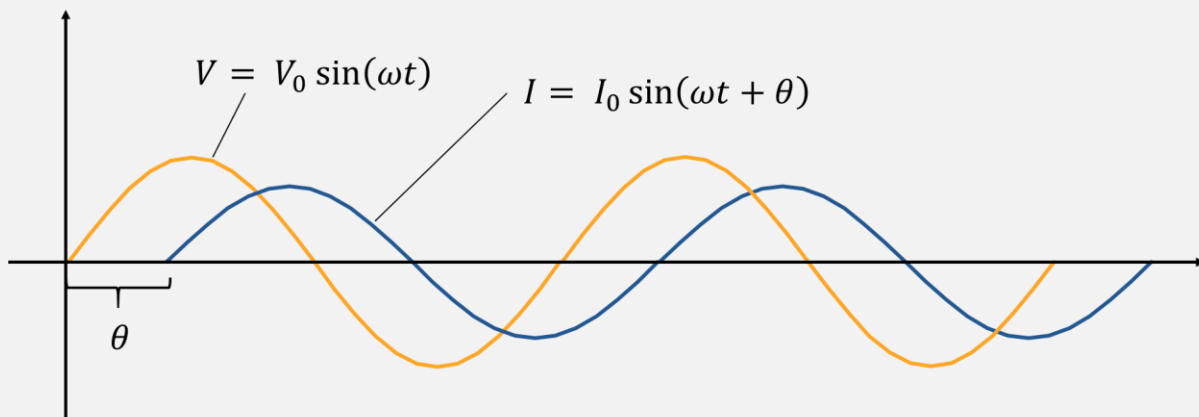

Figure 2.05 – AC voltage and current waveforms that are out of phase.

We can describe these waveforms using the equations shown below.

$$V(t) = V_0 \sin(\omega t)$$

$$I(t) = I_0 \sin(\omega t + \theta)$$

Power is the product of voltage and current, so we have that

$$P(t) = V_0 I_0 [\sin(\omega t) \cdot \sin(\omega t + \theta)]$$

To simplify this equation, we make use of the following trigonometric identities

$$\sin a \cdot \sin b = \frac{1}{2} [\cos(a - b) - \cos(a + b)]$$

$$\cos(a) = \cos(-a)$$

This then gives us

$$P(t) = \frac{V_0 I_0}{2} [\cos(\theta) - \cos(2\omega t + \theta)]$$

We also know that

$$\frac{V_0 I_0}{2} = \frac{V_0}{\sqrt{2}} \cdot \frac{I_0}{\sqrt{2}} = V_{RMS} \cdot I_{RMS}$$

This allows us to re-write the above power equation as

$$P(t) = V_{RMS} \cdot I_{RMS} \cdot [\cos(\theta) - \cos(2\omega t + \theta)]$$

This equation shows that the instantaneous power has two components. The first is constant and depends on the RMS values of the voltage and current and on the phase angle difference between them. The second component is time dependent, with a frequency twice that of the voltage and current waveforms.

The instantaneous power varies over time and is difficult to measure. Therefore, it is easier to consider the average power, which we can calculate averaging the above equation over one or more periods. Since the average value of any sinusoid is zero when calculated over one or more periods, we can see that the *average power for sinusoidal voltage and current* is simply:

$$\bar{P} = V_{RMS} \cdot I_{RMS} \cdot \cos(\theta)$$

Note that if the current and voltage are completely in-phase (theta is zero), then the average power value is simply the product of the RMS values of the voltage and current waveforms.

## AC Power Through a Resistor

The case of AC power through a resistor is simple to analyze since there is no phase difference between the current and voltage waveforms. For the resistor case the voltage, current and power waveforms have the form shown in the following figure.



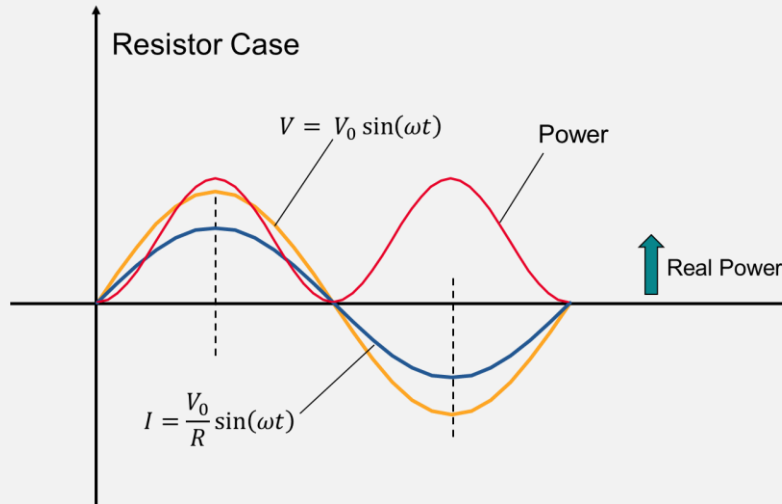

Figure 2.06 – The voltage, current and power waveforms for a resistor.

Since the voltage and current waveforms always have the same sign (either both positive or both negative), resistors can only generate real power.

### AC Power Through an Inductor

In the inductor case the current lags the voltage by  $\pi/2$  radians or 90 degrees, and the voltage, current and power waveforms have the form shown in the following figure.

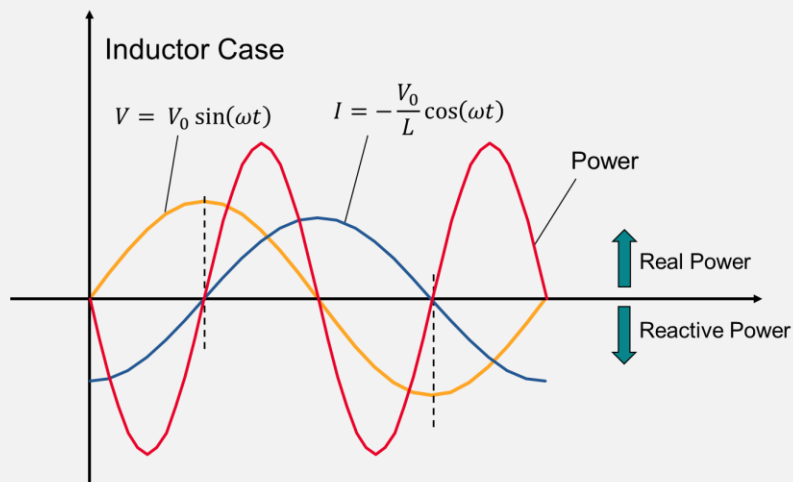

Figure 2.07 – The voltage, current and power waveforms for an inductor.

Although the inductor generates both real and reactive power, over an entire period they exactly balance out so that there is no net power dissipation. In the inductor case we can see that maximum

real power dissipation occurs at  $3\pi/4$  and  $7\pi/4$  radians, and maximum reactive power dissipation occurs at  $\pi/4$  and  $5\pi/4$  radians.

### AC Power Through a Capacitor

In the capacitor case the current leads the voltage by  $\pi/2$  radians or 90 degrees, and the voltage, current and power waveforms have the form shown in the following figure.

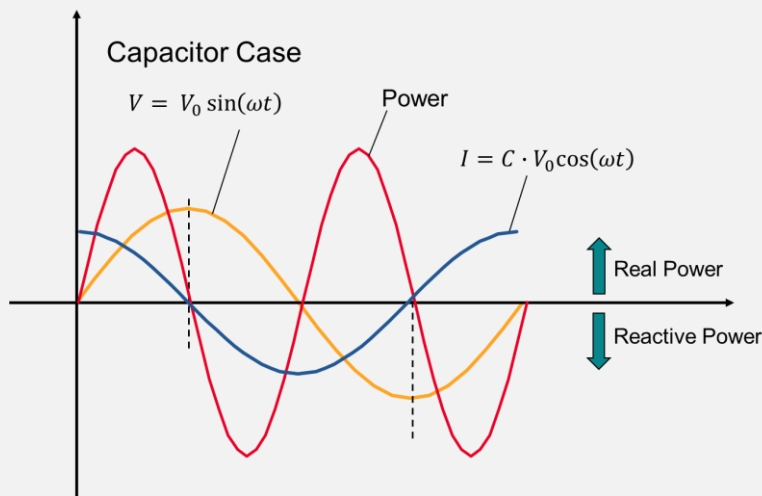

Figure 2.08 – The voltage, current and power waveforms for a capacitor.

As in the case of the inductor the capacitor generates both real and reactive power, but over an entire period they exactly balance out so that there is no net power dissipation. In the capacitor case we can see that maximum real power dissipation occurs at  $\pi/4$  and  $5\pi/4$  radians, and maximum reactive power dissipation occurs at  $3\pi/4$  and  $7\pi/4$  radians.

### Power Transmission

While power transmission can occur via either DC or AC voltages and currents, AC power transmission has been the standard since the beginning of the 20th century. The primary advantage of AC power transmission is the ease with which transformers (see Chapter 6) can step voltages up or down. It is more efficient to transmit power at higher voltages, and AC power transmission simplifies the up and down voltage transitions.

### Three-Phase Power

Single-phase power transmission is not as efficient a means to transmit power over long distances as is three phase power. To understand this, consider three sinusoidal waveforms (either voltage or current) shifted in phase from one another by 120 degrees.

Phase 1:  $\sin(\omega t)$

Phase 2:  $\sin\left(\omega t + \frac{2\pi}{3}\right)$

$$\text{Phase 3: } \sin\left(\omega t + \frac{4\pi}{3}\right)$$

Visually, these waveforms have the appearance shown below.

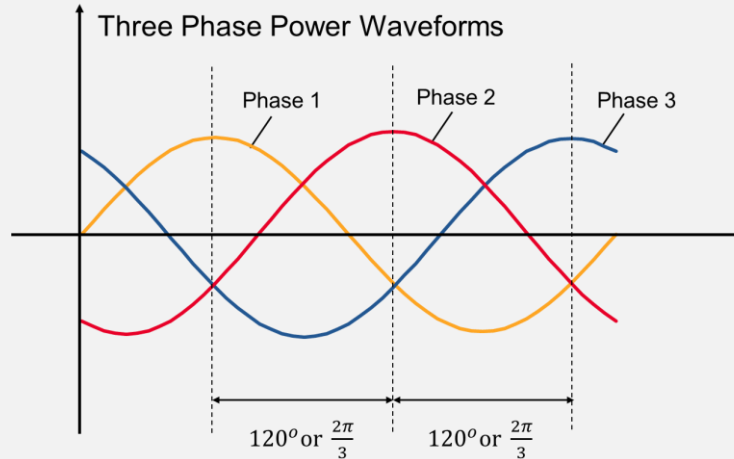

Figure 2.09 – Three phase power transmission waveforms.

We can show that the sum of the voltages and currents in a three-phase power system where all three phases are of equal amplitude and exactly 120 degrees apart always add up to zero. To do this we make use of the following trigonometric identity:

$$\sin(a + b) = \sin a \cdot \cos b + \cos a \cdot \sin b$$

This allows us to rewrite the equation for the phase 2 sine wave as follows:

$$\sin\left(\omega t + \frac{2\pi}{3}\right) = \sin \omega t \cdot \cos\left(\frac{2\pi}{3}\right) + \cos \omega t \cdot \sin\left(\frac{2\pi}{3}\right)$$

$$\sin\left(\omega t + \frac{2\pi}{3}\right) = -\frac{1}{2}\sin \omega t + \frac{\sqrt{3}}{2}\cos \omega t$$

Similarly, we can rewrite the equation for the phase 3 sine wave as follows:

$$\sin\left(\omega t + \frac{4\pi}{3}\right) = \sin \omega t \cdot \cos\left(\frac{4\pi}{3}\right) + \cos \omega t \cdot \sin\left(\frac{4\pi}{3}\right)$$

$$\sin\left(\omega t + \frac{4\pi}{3}\right) = -\frac{1}{2}\sin \omega t - \frac{\sqrt{3}}{2}\cos \omega t$$

Adding the equations for the phase 2 and phase 3 waveforms gives us:

$$\sin\left(\omega t + \frac{2\pi}{3}\right) + \sin\left(\omega t + \frac{4\pi}{3}\right) = -\sin \omega t$$

Obviously, adding this to the equation for phase 1 yields a net value of zero. Of course, this result relies on all three phases possessing exactly the same magnitude and being precisely 120 degrees (or  $\frac{2\pi}{3}$  radians) apart in phase. In real-world systems there is always some mismatch so that the instantaneous current from all three sources does not add up to exactly zero.

One common way to connect three-phase lines together is in what is known as the Wye or Star Connection as shown below.

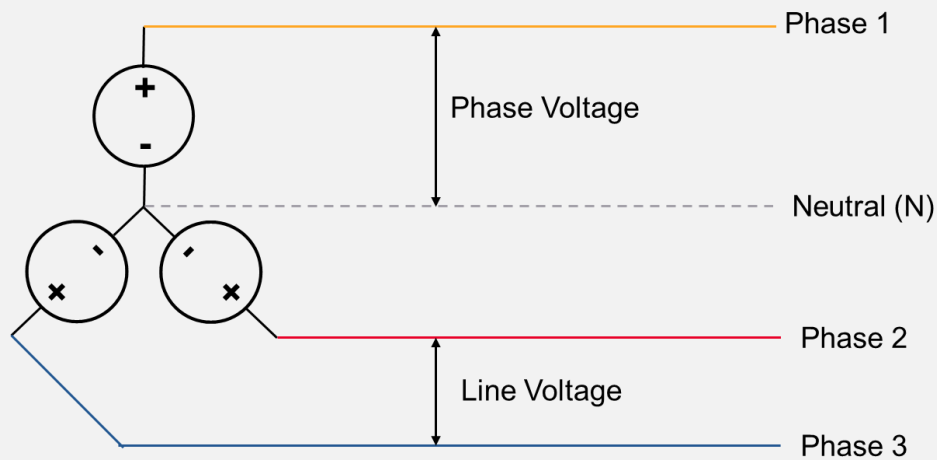

Figure 2.10 – The Wye or Star connection of a three-phase power system.

In this configuration the neutral line can be very small, since the sum of the return currents is close to zero. In a three-phase system the voltage between any two of the phase lines is known as the line voltage, while the voltage between any phase line and the neutral line is known as the phase voltage.

Suppose we have a three-phase system with a phase voltage amplitude of 120 V. It is then easy to calculate the line voltage amplitude using trigonometric identities:

$$\sin(\theta) - \sin\left(\theta + \frac{2\pi}{3}\right) = 2 \cdot \cos\left(\frac{\theta + \left(\theta + \frac{2\pi}{3}\right)}{2}\right) \sin\left(\frac{\theta - \left(\theta + \frac{2\pi}{3}\right)}{2}\right)$$

$$\sin(\theta) - \sin\left(\theta + \frac{2\pi}{3}\right) = -\sqrt{3} \cos\left(\theta + \frac{\pi}{3}\right)$$

We can see that if we measure the voltage difference between any two sinusoidal lines shifted by 120 degrees then we need to multiply their phase voltage by the square root of three. Therefore, we can easily calculate the amplitude of the line voltage:

$$120\text{ V} \times \sqrt{3} = 208\text{ V}$$

Many industrial and some consumer applications use the 208 V/120 V three phase system.

The fact that the sum of the voltages and currents in a three-phase system is near zero is its key advantage in transmitting power. Suppose we want to transfer power using three single-phase supplies as shown below.

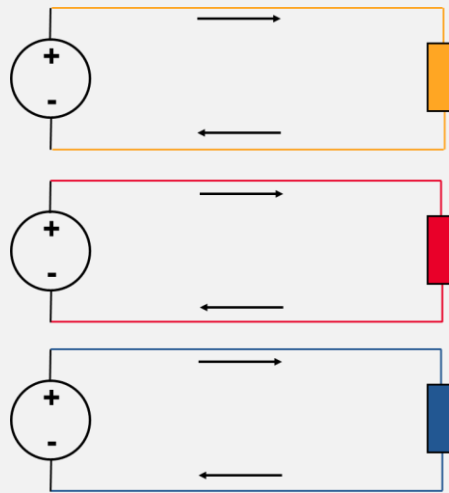

Figure 2.11 – Transmitting power from three single-phase sources into three separate loads.

This system requires a total of six wires, and (assuming all of the supplies are identical) each wire needs to be the same size. However, we can transmit the same amount of power in a three-phase system using only four wires:

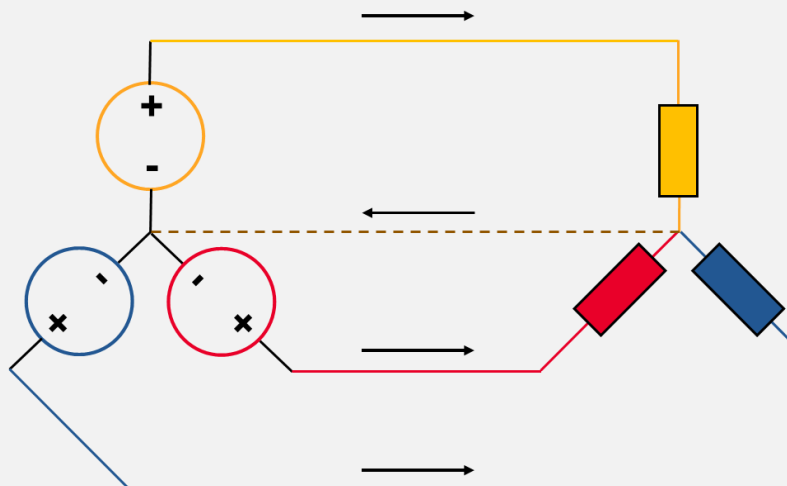

Figure 2.12 – Transmitting power from a three-phase generator into a three-phase load.

Not only does this configuration reduce the number of wires needed from six to four, but the reference or return path wire (shown as dashed line in this diagram) can be of smaller size than the three main

transmission lines since it only has to handle current due to amplitude and phase mis-matches in the three-phase system.

It is also possible to connect three phase sources and loads in a Delta configuration as shown in the following figure.

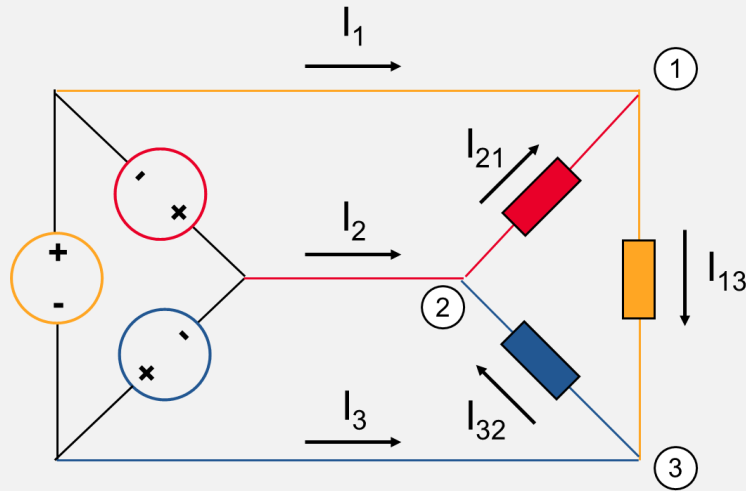

Figure 2.13 – Three phase power transmission Delta configuration.

The sum of the three phase voltages is zero, and the Delta configuration takes advantage of the fact that voltage sources sum in series. Kirchhoff's current law then allows us to calculate the currents flowing in the various loads:

$$I_1 = I_{13} - I_{21}$$

$$I_2 = I_{21} - I_{32}$$

$$I_3 = I_{32} - I_{13}$$

Analyzing three-phase power systems can be difficult or impossible using a conventional oscilloscope, so specialized instruments exist for this purpose. For example, Keysight's PA2203A IntegraVision Power Analyzer has four channels each capable of measuring voltage, current and power. A power analyzer measures parameters such as:

- AC and DC power consumption
- Power conversion efficiency
- Start up and turn on characteristics
- Common AC power parameters:
  - Frequency
  - Phase
  - Power Factor
  - Harmonics

For more information on Keysight power analyzers please refer to Appendix A.

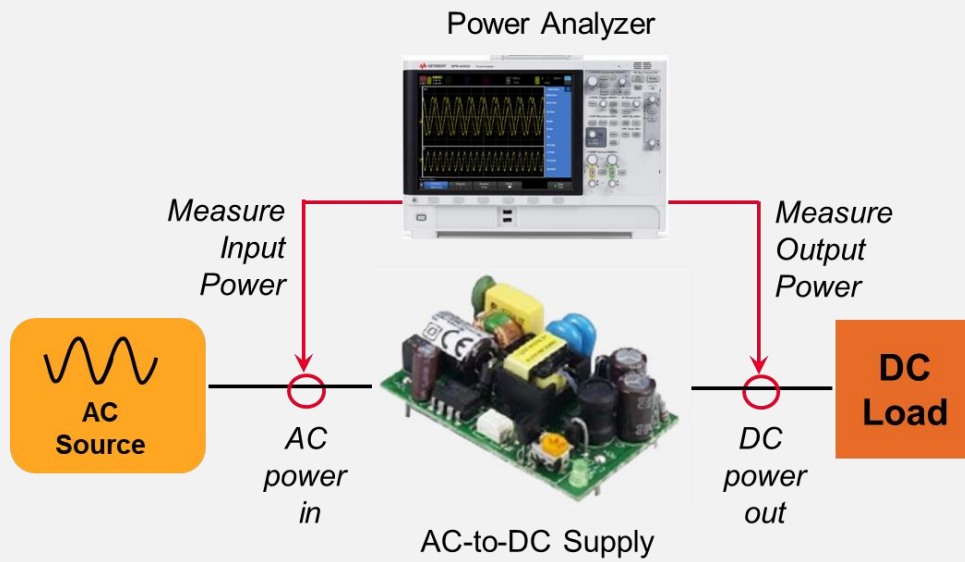

Figure 2.14 – A power analyzer simplifies tasks such as evaluation of an AC-to-DC power supply.

## Chapter 3 – DC Power Supplies

### Introduction

In a very broad sense, you can define power supplies as circuits that transform electrical input power (AC or DC) into electrical output power (AC or DC). Excluded from this definition are power supplies based on rotating machine principles and power supplies that derive electrical power from other energy forms (e.g., batteries, solar cells, fuel cells, etc.). Based on these considerations, we can divide electronic power supplies into four broad classifications:

1. AC in, AC out-line regulators and frequency changers
2. DC in, DC out-converters and DC regulators
3. DC in, AC out-inverters
4. AC in, DC out

This last category is by far the most common of the four and is generally the one referred to when speaking of a "DC power supply". It is also the one to which this chapter is specifically devoted. Chapter 6 (which deals with power conversion) will discuss the other three.

### Linear vs. Switching Power Supplies

The most fundamental choice you need to make when selecting a DC power supply is whether to use a linear or switching DC power supply. While many people believe that a linear DC power supply is the only option for applications requiring low noise, modern switching DC power supplies offer surprisingly good noise performance. Therefore, other factors (such as power supply size and cost) often have equal weight in terms of selection criteria. However, before continuing it is important to understand the operating principles of both types of power supplies.

#### Linear Power Supply Operation

The basic operation of a linear power supply is simple in concept and implementation as compared to that of a switching power supply. We can break down the transformation of AC power into regulated DC power in a linear power supply into the following steps:

1. A transformer scales the AC line voltage to a value consistent with the required maximum DC output voltage level.
2. The AC voltage then gets rectified into DC voltage.
3. Large electrolytic capacitors filter much of the AC ripple voltage superimposed on the unregulated DC voltage.
4. Series-pass power transistors control the difference between the unregulated DC rail voltage and the regulated DC output voltage. There always needs to be some voltage across the series pass transistors for proper regulation.
5. An error amplifier compares the output voltage to a reference voltage to regulate the output at the desired setting.



6. Finally, an output filter capacitor further reduces AC output noise and ripple, and lowers output impedance, for a more ideal voltage source characteristic.

The following figure shows a generic linear power supply topology.

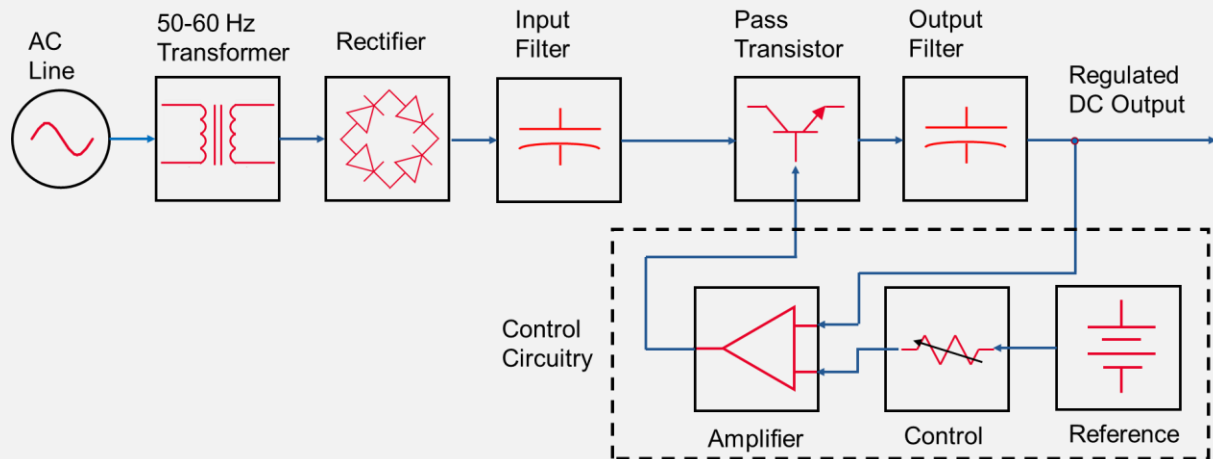

Figure 3.01 – Basic linear DC power supply circuitry.

Linear DC power supply design is well established, with the only on-going innovations focused on improving efficiency and thermal management. Due to their straightforward configuration, properly implemented linear power supplies possess some inherent advantages:

- Fast output transient response to AC line and output load changes
- Low output noise and ripple voltage, and primarily having low frequency spectral content
- Very low common mode noise current
- Cost competitive at lower output power levels (under about 500 watts)

Of course, as with any real-world instrument linear power supplies also have some inherent disadvantages:

- Low power efficiency (typically no better than 60% at full output voltage and decreases with lower output voltage settings)
- Relatively large physical size and weight
- High cost at higher power (above about 500 watts)

This might make it sound as if linear power supplies are always the optimal choice, but before we conclude this we need to understand the topology and merits of switching power supplies.

## Switching Power Supply Operation

Switching power supply operation is more complex as compared to that of a linear power supply. We can break down the transformation of AC power into regulated DC power in a switching power supply into the following steps:

1. The AC line voltage gets rectified and then filtered to provide an unregulated high voltage DC rail to power the following DC-to-DC inverter circuit.
2. Power transistors switching at 10's to 100's of kHz impose a high voltage, high frequency AC pulse waveform on the transformer primary (input).
3. The transformer turns ratio scales the AC pulse voltage to a value consistent with the required DC output voltage.
4. A rectifier circuit turns the transformer secondary (output) AC voltage into a pulsed DC voltage.
5. An LC (inductor-capacitor) output filter averages the pulsed voltage into a continuous DC voltage at the power supply's output.
6. As with a linear power supply, an error amplifier compares the DC output voltage against a reference to regulate the output at the desired setting.
7. A modulator circuit converts the error amplifier signal into a high frequency, pulse width modulated waveform to drive the switching power transistors.

The following figure shows a generic switching power supply topology.

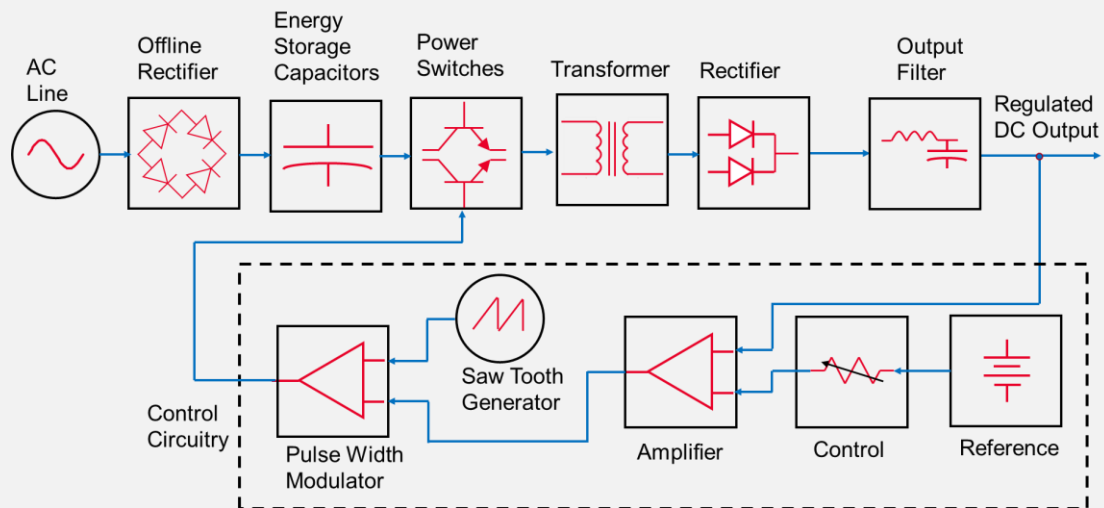

Figure 3.02 – Basic switching DC power supply circuitry.

Despite their added complexity, the much higher operating frequencies of switching power supplies (several orders of magnitude greater than that of linear power supplies) allows them to use much smaller magnetic and filtering components. This instills switching DC power supplies with some important advantages:

- High power conversion efficiency of typically 85%, relatively independent of output voltage setting.
- Small size and lightweight, especially at higher power.
- Cost effective, especially at higher power.

As in the case of linear power supplies, switching DC power supplies also have some typical disadvantages:

- High output noise and ripple voltage
- High common mode noise current
- Slow transient response to AC line and DC output load changes.

For the above reasons, traditional switching DC power supplies focused on optimizing cost, efficiency and size, since these are the areas where linear power supplies suffer. As a result, performance was often a secondary consideration. However, modern technologies (more advanced switching topologies, careful design, and better filtering) have enabled high-performance switching DC power supplies to offer specifications that compare very favorably with those of linear DC power supplies. Since one key specification that differentiates these two types of power supplies is common mode current noise, that is the topic we will discuss next.

### Common Mode Current Noise

Common mode noise is inherent in all test setups (even those where users have paid careful attention to eliminate ground loops). Common mode noise current can be an important consideration when selecting a DC power supply, and it is one area where linear DC power supplies generally outperform switching DC power supplies. As shown in the following figure, common mode noise current ( $I_{CM}$ ) flows from both of the power supply's output leads and returns to the supply via earth ground.

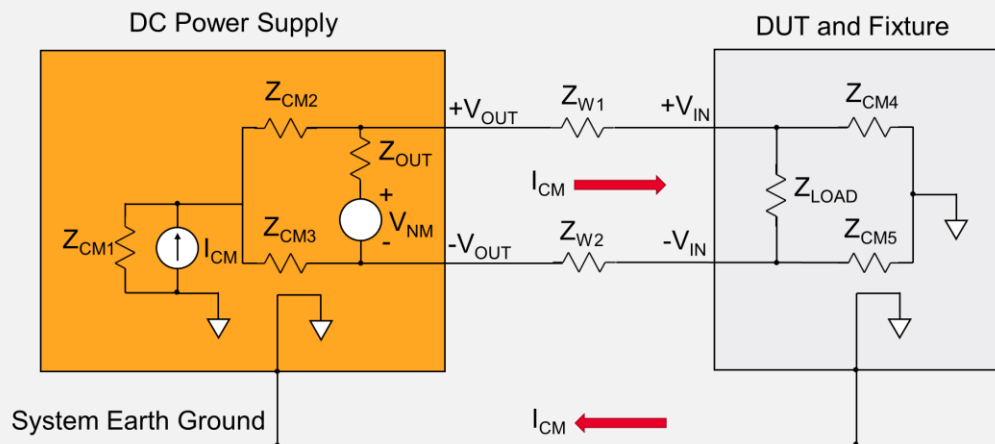

Figure 3.03 – Common mode current noise flowing from a DC power supply

Low-end switching DC power supplies often generate large amounts of common mode noise current. High voltage slewing (dv/dt) of the switching transistors capacitively couples through to the output, and in extreme cases this can generate hundreds of milliamps of peak-to-peak high frequency current. In contrast, properly designed linear DC power supplies usually generate only microamps of peak-to-peak of common mode noise current. However, it is important to understand an improperly designed or low-end linear DC power supply can generate several milliamps of peak-to-peak common mode noise current. Also, high-performance switching DC power supplies can achieve performance similar to that of linear DC power supplies, generating just a few milliamps of common mode noise current.

Common mode noise current can create problems when it shows up as high frequency voltage spikes superimposed on the DC output voltage. The voltage spikes are proportional to the magnitude of current and imbalance in impedances in the path to the DUT. The microamp common mode noise levels of linear DC power supplies are in general negligible, whereas the milliamp common mode noise currents generated by switching DC power supplies can create issues. Under some conditions they can become more significant than the differential mode noise voltage also present. Since many people misunderstand or ignore common mode current noise, users sometimes get the incorrect impression that all switching DC power supplies are unsuitable for their needs based on their experience with one supply that had high levels of common mode noise current.

In most practical applications switching DC power supply common mode noise is not as big an issue as you might expect. For one thing, many applications (such as telecommunications and digital information systems) that use traditional switching DC power supplies are reasonably insensitive to it. For situations where common mode noise is more critical, the much lower levels of modern high-performance switching DC power supplies makes it a non-issue in all but the most noise sensitive applications. Even in cases common mode noise is problematic (such as extremely sensitive analog circuitry), adding filtering can often solve this issue. This allows you to take advantage of the many benefits offered by switching DC power supplies. Filtering also mitigates the effects of other noise sources present (such as AC line EMI and ground loop pickup), which are present regardless of the type of power supply used.

## Summary and Power Supply Trade-Offs

In the previous three sections we discussed the relative merits of linear and switching DC power supplies along with the issue of common mode noise. We now have enough knowledge to make some intelligent comparisons and trade-offs. The following two tables summarize some of the key qualitative and quantitative properties of the power supplies that we discussed.

	Advantages	Disadvantages
Linear DC power supply	<ul style="list-style-type: none"> <li>• Fast output transient response</li> <li>• Low output noise and ripple voltage</li> <li>• Low common mode noise current</li> <li>• Cost competitive at lower output power levels (&lt;500 W)</li> </ul>	<ul style="list-style-type: none"> <li>• Low efficiency (typically no better than 60% at full output and decreasing with lower output voltage settings)</li> <li>• Large physical size and weight</li> <li>• Higher cost at higher power (&gt;500 W)</li> </ul>
Traditional switching DC power supply	<ul style="list-style-type: none"> <li>• High efficiency (typically 85% or better independent of the output voltage settings)</li> <li>• Small size and light weight, especially at higher power</li> <li>• Cost-effective, especially at higher power</li> </ul>	<ul style="list-style-type: none"> <li>• High output noise and ripple current</li> <li>• High common mode noise current</li> <li>• Slow transient response to AC line and DC output load changes</li> </ul>
High-performance switching DC power supply	<ul style="list-style-type: none"> <li>• High efficiency (typically 85% or better independent of the output voltage settings)</li> <li>• Small size and light weight, especially at higher power</li> <li>• Fast output transient response</li> <li>• Low output noise and ripple voltage</li> </ul>	<ul style="list-style-type: none"> <li>• Typically, higher cost</li> </ul>

Parameter	Linear	Traditional Switching	High-Performance Switching
Transient response speed (to 0.15% of final value)	50-100 $\mu$ s	1-2 ms	<100 $\mu$ s
Periodic and random deviation* <sup>1</sup> (20 Hz - 20 MHz)	0.3 - 1 mV <sub>rms</sub> / 3 - 15 mV <sub>pp</sub>	10 - 20 mV <sub>rms</sub> / 75 - 100 mV <sub>pp</sub>	1 mV <sub>rms</sub> / 6 mV <sub>pp</sub>
Common mode noise current (20 Hz - 20 MHz)	Up to 10's of $\mu$ A <sub>pp</sub>	Up to 100's of mA <sub>pp</sub>	Less than a few mA <sub>pp</sub>

\*<sup>1</sup> Based on 50 V output voltage

So now that we have presented the trade-offs between linear, traditional switching and high-performance switching DC power supplies, it should be clear that the best choice for a particular application depends upon many parameters. Also, since modern high-performance switching DC power supplies can match the specifications of linear DC power supplies in almost all aspects, it is hard to justify the added size, weight and cost of linear DC power supplies (especially at high power levels). In the final analysis the choice of what type of power supply to use for a given application requires a careful analysis of performance, space and cost tradeoffs, and the decision should not simply be based on topology (i.e. linear versus switching).

## Keysight's Ultra-Low Noise Sources

Keysight has two ultra-low noise sources that illustrate the capabilities of modern switching power source design. The B2961B (one-channel) and B2962B (two-channel) 6.5 Digit Low Noise Power Sources, when used with one of the optional ultra-low noise filters (UNLFs), can source voltage with noise of less than  $10 \mu\text{Vrms}$  in the frequency range of 10 Hz – 20 MHz. You can use this outstanding low noise performance to evaluate noise-sensitive devices and circuits such as analog-to-digital converter circuits, as well as many other types of analog and RF ICs. As the following figure shows, when used with the UNLFs the B2961B and B2962B can also minimize the noise density to 1 nVrms/ $\sqrt{\text{Hz}}$  at 10 kHz, which is necessary for the phase noise evaluation of oscillator circuits such as VCOs, crystal oscillators, etc.

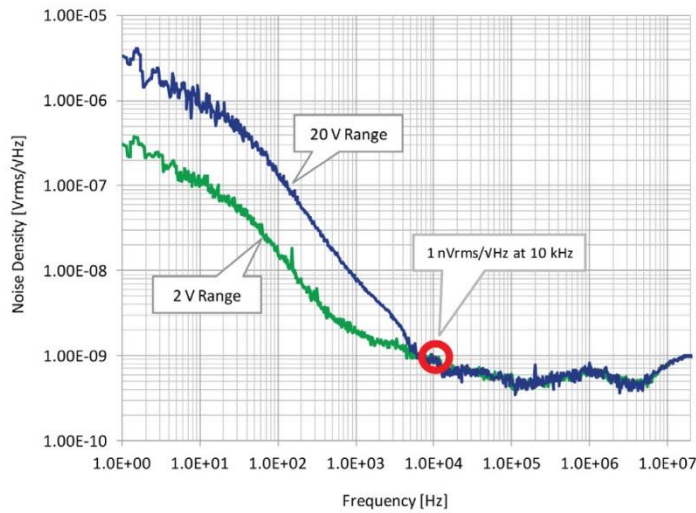

Figure 3.04 – The B2961B and B2962B possess excellent noise performance when used with their optional ultra-low noise filters.

## Output Characteristics

A power supply output characteristic defines a region that contains all valid voltage and current combinations for that power supply output. Any voltage-current combination that exists within the output characteristic is a valid operating point for that power supply. There are three main types of power supply output characteristics: rectangular, multiple-range, and autoranging. Of these three, the rectangular output characteristic is the most common. However, before discussing the different output characteristics we first need to understand the different operating quadrants.

### Operating Quadrants

We typically divide the current-voltage (IV) plane into four regions. Power supplies operate in the first quadrant (both positive voltage and current output). An electronic load operates in the second quadrant, with positive voltage and negative current output. Some power supplies are capable of operating in both quadrants, effectively acting as both supplies and loads. We denote these types of power supplies as two-quadrant power supplies. Quadrants three and four are important when testing semiconductor devices (for example the breakdown voltage on a transistor when applying a negative voltage). The following figure shows a plot of the IV plane and the different operating quadrants.

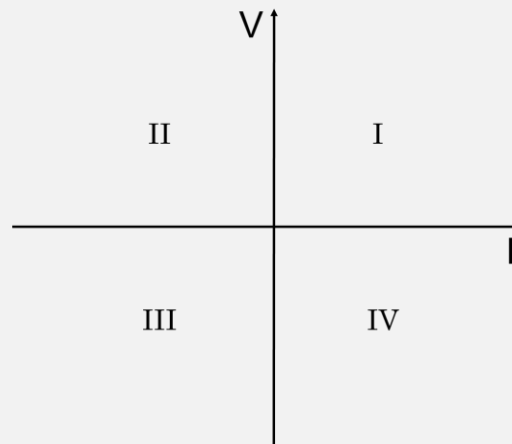

Figure 3.05 – The four operating quadrants.

### Rectangular output characteristic

As its name implies, a rectangular output characteristic appears as a rectangle when plotted on a voltage-current graph. These supplies produce maximum power at a single point defined by the maximum voltage and maximum current values. For example, suppose you have a 20 V, 5 A, 100 W power supply with a rectangular output characteristic. The voltage can be set to any value from 0 to 20 V, and the current can be set to any value from 0 to 5 A. Since  $20\text{ V} \times 5\text{ A} = 100\text{ W}$ , there is a singular maximum power point that occurs at the maximum voltage and current settings.

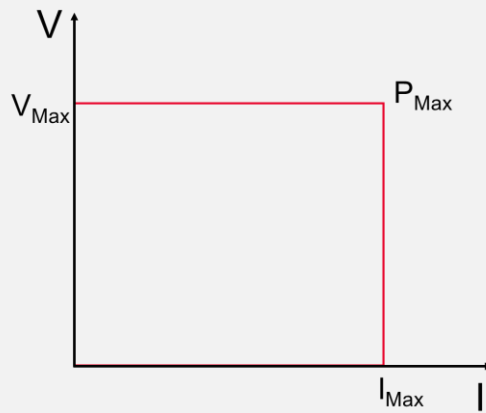

Figure 3.06 – The output characteristic of a rectangular power supply.

### Multiple-range output characteristic

A multi-range output characteristic is slightly more complicated than that of a rectangular output characteristic, resembling two or more overlapping rectangular output characteristics when plotted on a voltage-current graph. Therefore, it has multiple maximum power points that occur at multiple voltage-current combinations. The following figure shows an example of a multiple-range output characteristic with two ranges, which is also known as a dual-range output characteristic. The advantage of a power supply with this type of output characteristic is its extended output range capabilities when compared to a power supply with a rectangular output characteristic. It can cover more voltage-current combinations without the additional expense, size, and weight of a higher power rectangular output characteristic power supply. So, even though you can set voltages up to  $V_{max}$  and currents up to  $I_{max}$ , the combination  $V_{max}/I_{max}$  is not a valid operating point. That point is beyond the power capability of the power supply and it is outside the operating characteristic.

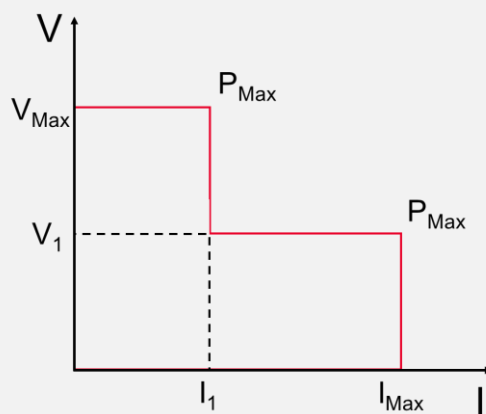

Figure 3.07 – The output characteristic of a multiple-range power supply (two range example).



## Autoranging output characteristic

An autoranging power supply has a maximum voltage and a maximum current, but it cannot output both at once. The autoranger's maximum output power (which is the product of voltage and current) determines the output characteristic between the maximum voltage and maximum current points. This gives the curve between the maximum voltage and maximum current points a hyperbolic shape as shown in the following figure.

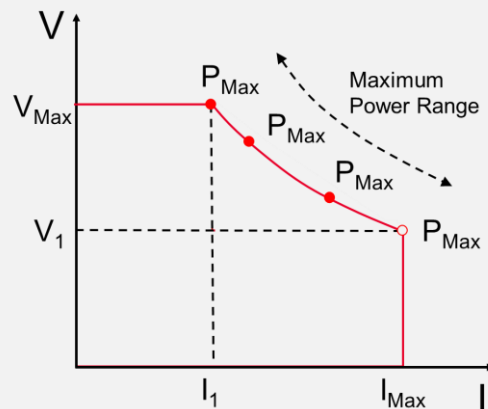

Figure 3.08 – The output characteristic of an autoranging power supply.

For applications requiring a large range of output voltages and currents within a fixed power limit, an autoranging power supply is a great choice. A good example of a DUT requiring a wide range of voltages and currents is a DC-DC converter. At maximum power out, a DC-DC converter with a nominal input voltage of 24 V consumes a relatively constant power even though its input voltage can vary from 14 V to 40 V. During testing, this wide range of input voltages creates a correspondingly wide range of input currents even though the power is not changing much. Different DC-DC converters in the same power family can have nominal input voltages of 12 V, 24 V, or 48 V, resulting in input voltages as low as 9 V (requiring a large current), and as high as 72 V (requiring a small current). For DC-DC converters large voltages and currents are both needed, but not at the same time.

## Modes of Operation

Power supplies operate in one of three modes: constant voltage (CV), constant current (CC) or unregulated (UNR). It is important to understand that, while you can program a power supply to operate in a specific mode, it may not operate in that mode. Power supplies typically have a maximum current and a maximum voltage output as well as a maximum power output determined by the intersection of those two lines. The intersection also defines the value of the critical or crossover resistance. The following graph illustrates these important parameters.

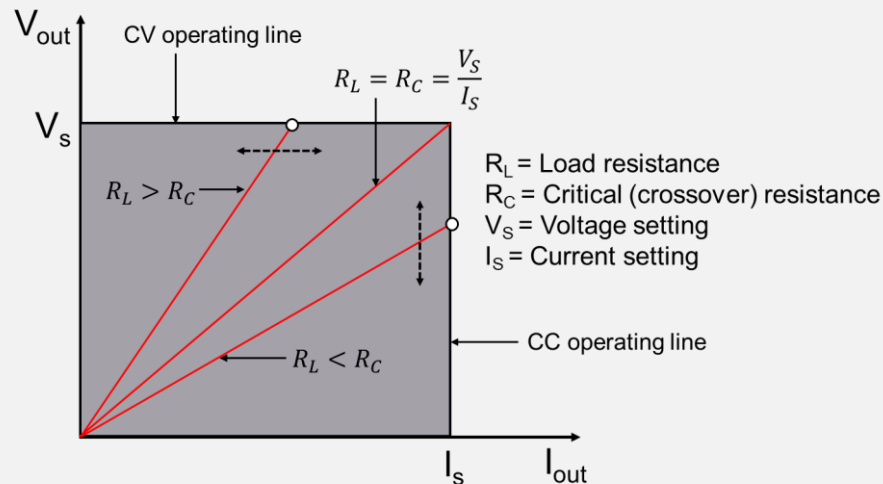

Figure 3.09 – Power supply operating modes.

While you can set a power supply to behave in constant current or constant voltage mode, the mode it actually operates in is determined by the load and crossover resistances as follows:

- **Constant Voltage (CV):** If you set a power supply to constant voltage mode, then the formula  $I_{out}$  equals  $V_s$  over  $R_L$  determines the output current as long as  $R_L$  is greater than  $R_C$  (the crossover resistance).
- **Constant Current (CC):** If you set a power supply to constant current mode, then the formula  $V_{out}$  equals  $I_s$  times  $R_L$  determines the output current as long as  $R_L$  is less than  $R_C$  (the crossover resistance).
- **Unregulated (UNR):** If the power supply is not operating at its voltage or current set point, then it is operating in unregulated mode and its output is unpredictable. There are a number of possible reasons that a power supply can be in unregulated mode:
  - A power supply internal fault
  - Insufficient AC input line voltage
  - The load resistance ( $R_L$ ) is equal to the crossover resistance ( $R_C$ )
  - An incorrectly connected parallel power source
  - The power supply is operating at the mode crossover point

Therefore, if you set your power supply to operate in constant voltage or constant current mode but it is operating in unregulated mode, then you should use the above list as a starting point to determine the possible cause(s).

## Understanding Ohmic Voltage Drop

Many times we tend to treat all wires as perfect conductors, but in practice this is not true. Even wires composed from materials such as copper have a non-zero resistance associated with them. In fact, if you pass a sufficiently large current through any wire (as is many times the case with power supplies), then then you can create a significant voltage drop. A large voltage drop in a DC power supply's wires can impact the voltage fed back to the power supply, resulting in a lower voltage than programmed. While four-wire measurement techniques can correct for this error, before we discuss this it is useful to understand the basics of wire gauge and length.

### Wire gauge and length

American Wire Gauge (AWG) is a wire sizing standard that has existed in the U.S. since the 1850s. The sizes step logarithmically, but the important points to understand are:

- The higher the gauge number the smaller the diameter of the wire. This is due to the fact that the gauge number is based on the resistance of the wire, NOT on its diameter.
- With every 3-gauge increase in AWG value the resistance of the wire roughly doubles.

The following table shows the resistance of wire (in milli-Ohms per foot) for various gauges.

American Wire Gauge (AWG) Value	Resistance (mΩ/ft)
22	16.1
20	10.2
18	6.39
16	4.02
14	2.53
12	1.59
10	0.999

## Eliminating Ohmic voltage drop

To eliminate the effects of Ohmic line drop you need to use a method known as 4-wire (or Kelvin) remote sensing. The basic principle of this technique is to use a separate pair of wires to sense the voltage on the DUT, with no current flowing in the sense wires. Since no current is flowing in the sense wires, there can be no voltage drop and the voltage value read back at the power supply (or electronic load) is the true value that you are applying to the DUT.

The following figure shows an example where a DC power supply is outputting 10 Amps at 5 Volts, but due to Ohmic drops in the leads the DUT is only seeing 4.7 Volts. Assuming the power supply has separate sense leads (as shown in this example), how do we fix this?

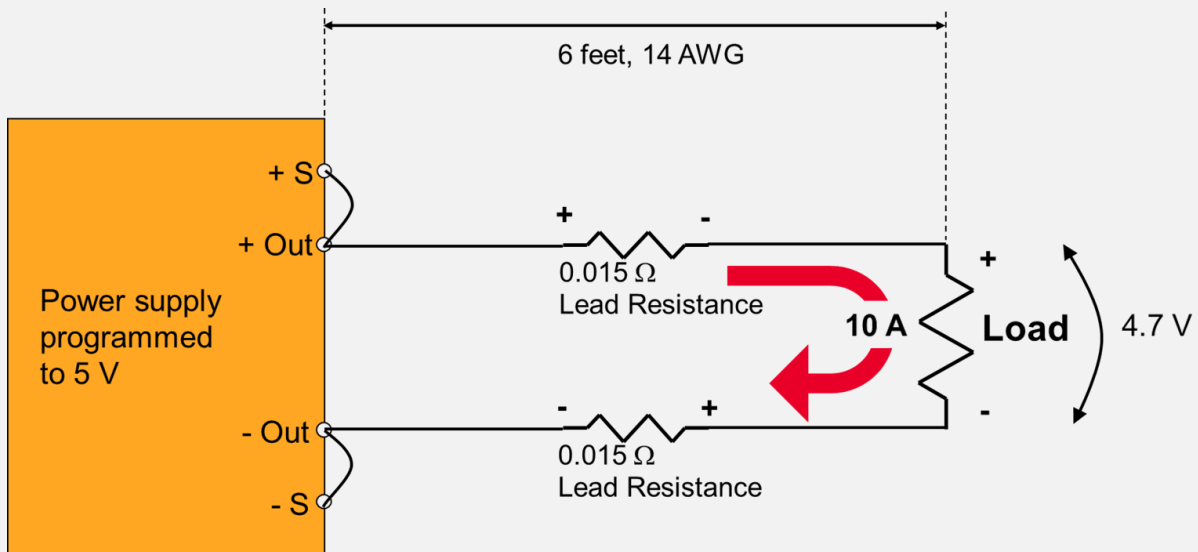

Figure 3.10 – The effect of Ohmic line drops when not using the 4-wire measurement technique.

Most high-end power supplies have separate sense lines associated with their high and low outputs. As shown in the previous figure, normally we connect these to the main outputs. However, when making 4-wire measurements the sense leads need to connect to the DUT through separate leads. Since no current flows through the sense leads, there is no Ohmic drop through them. The sense lines therefore feed the exact voltage on the DUT back into power supply's internal circuitry to ensure that the programmed voltage is what the DUT sees. The following figure shows the benefit of using the 4-wire measurement technique.

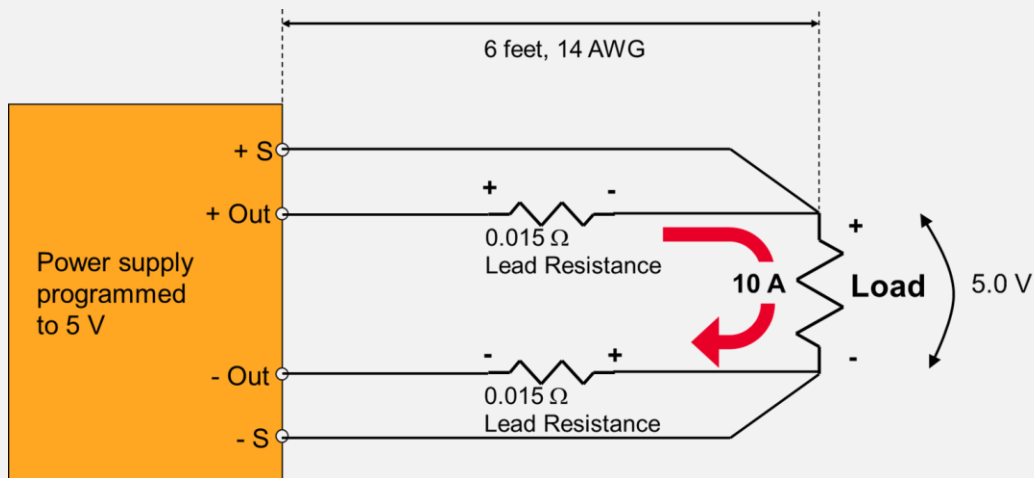

Figure 3.11 – The 4-wire measurement technique eliminates the effects of Ohmic line drops on load voltage.

Note that in some cases (it depends on the supply – refer to the supply’s data sheet) you may have to set the power supply to remote sense mode in order to use the sense inputs. In other cases it will be automatic.

There are a few other caveats that you should keep in mind when making 4-wire measurements:

- Use two-wire twisted shielded cable
- Do not twist or bundle sense leads together with load leads

Most power supplies can compensate for several volts of drop in the leads, but you should check the data sheet for exact numbers.

## Protection Features

Protection settings are an important feature of modern DC power supplies that some users do not completely understand. However, they can be invaluable in protecting sensitive DUTs from inadvertent voltage or current surges. An important point to clarify is that over-voltage protection (OVP) and over-current protection (OCP) settings DO NOT operate in the same manner as compliance settings operate on source/measure units (SMUs). In the case of SMUs the compliance setting will limit the output but not shut it off (unless the user activates certain specific settings telling it to do so). In contrast, on a power supply the OVP and OCP settings will cause the power supply output to shut off completely.

### Over Voltage Protection (OVP)

The over voltage protection feature is always enabled for power supplies and you cannot disable it. The OVP circuitry operates completely independently of the voltage limit circuitry, and it will shut the power supply output off when the power supply output voltage exceeds the OVP setting. However, it is important to understand that in general the power supply uses the voltage at its outputs (not its sense terminals) to make this judgement. Therefore, if you are using a 4-wire connection and have significant voltage drop in your leads you need to account for this in your over-voltage protection setting. To

prevent the OVP feature from activating, you need to set it at a value that is greater than that of the maximum expected operating point of your power supply. The following figure illustrates this point.

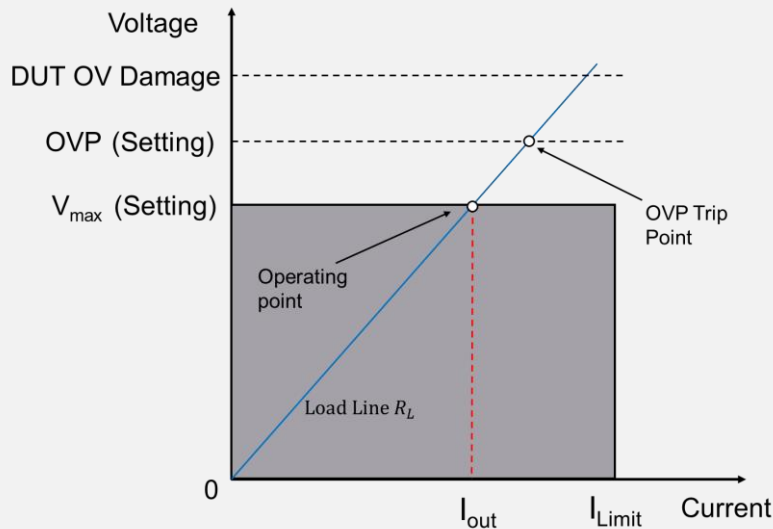

Figure 3.12 – Set the OVP value greater than the maximum expected value of your power supply.

Of course, as this illustration shows it is important to also make sure that the OVP setting is below the level of voltage that will cause damage to your DUT. OVP has to be fast in order to prevent device damage, so the typical response time of a DC power supply to its OVP setting is a few microseconds.

### Over Current Protection (OCP)

The over-current protection feature operates similarly in that it will shut the power supply output off when the power supply output current exceeds the OCP setting. However, there are some important differences between the operation of the OVP and OCP circuits. Unlike the OVP system (which operates totally independent of the voltage limit control system), it is the current limit control system that triggers the OCP system. Therefore, the OCP response time includes the response time of the current limit circuitry in addition to that of the OCP circuitry. Typically, OCP response times are in the milliseconds (as opposed to microseconds for the OVP response time). Fortunately, in general DUTs are far less sensitive to damage from too much current than they are to too much voltage. Although there are always exceptions, for most DUTs the slower response at lower overloads is generally not an issue.

If you need to improve OCP response time then here are some suggestions:

1. Avoid using a power supply that has a full output current rating that is much larger than what your DUT actually draws. This makes the overdrive from an overload a greater percentage of the full output current rating, which normally cause the current limit circuit to respond more quickly.
2. Evaluate different models of power supplies to determine how quickly their various current limit circuits and OCP systems respond to your DUT protection needs. Different models of

power supplies will have different response times, since the response at low levels of overdrive is determined by the response of the current limit circuit.

3. Use an OCP system that operates independently of the current limit circuit (similar to the way in which the OVP circuit works). This requires a circuit that compares the output current against the protection level and shuts down the output immediately if it exceeds that value is. Unfortunately, this type of OVC protection is not available on commercially available DC power supplies and would require the creation of a custom protection circuit.

### Combining Supplies in Series and Parallel

You may occasionally need more voltage and/or current from your DC power supplies than they are capable of supplying. A reasonable question to ask is: Can I combine the supplies I have together in series or parallel to achieve more voltage or current? The answer is yes as long as you observe the proper procedures.

#### Connecting power supplies in series for more voltage

You can combine power supplies in series to increase the total power (voltage) that they can deliver. The following figure illustrates the correct connections to achieve this.

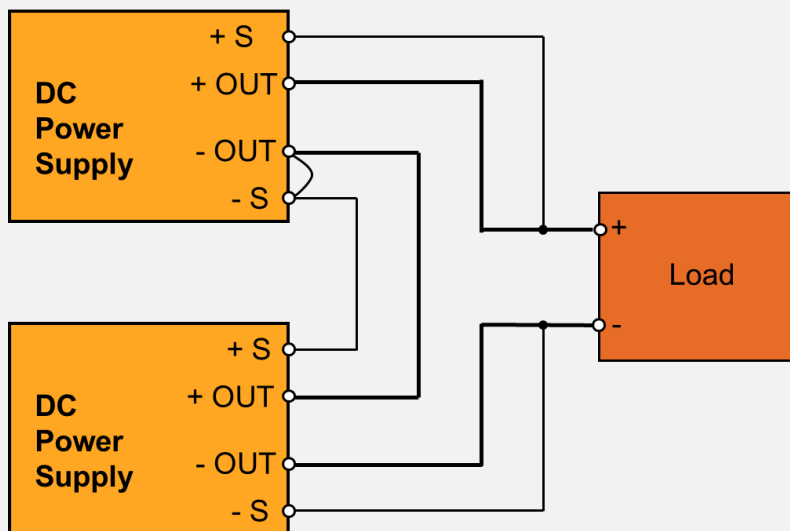

Figure 3.13 – Connecting power supplies in series to achieve more voltage output.

Of course, you need to set each power supply output independently so that the voltages sum to the total desired value. To do this, first set each output to the maximum desired current limit the load can safely handle. Next, set the voltage of each output to sum to the total desired voltage. For example, if you are using two outputs, set each to one half the total desired voltage. If you are using three outputs, set each to one third the total desired voltage. In addition, when you connect outputs in series for higher voltage, you should also observe the following precautions:

- Never exceed the floating voltage rating (output terminal isolation) of any of the outputs
- Never subject any of the power supply outputs to a reverse voltage

- Only connect outputs that have identical voltage and current ratings in series
- If using remote sensing, make sure to wire the remote sense terminals on each output in series and connect them to the load
- Keep the wiring from the power supplies to the load as short as possible and twist or bundle the leads to reduce lead inductance and noise pickup. The goal is to always minimize the loop area or physical space between the + and - output leads from the power supply to the load.

### Connecting power supplies in parallel for more current

You can also connect power supplies in parallel to supply more current to a DUT. Set the current limit of all outputs equally so they sum to the total desired current limit value. The following figure shows a diagram of two DC power supplies connected correctly in parallel:

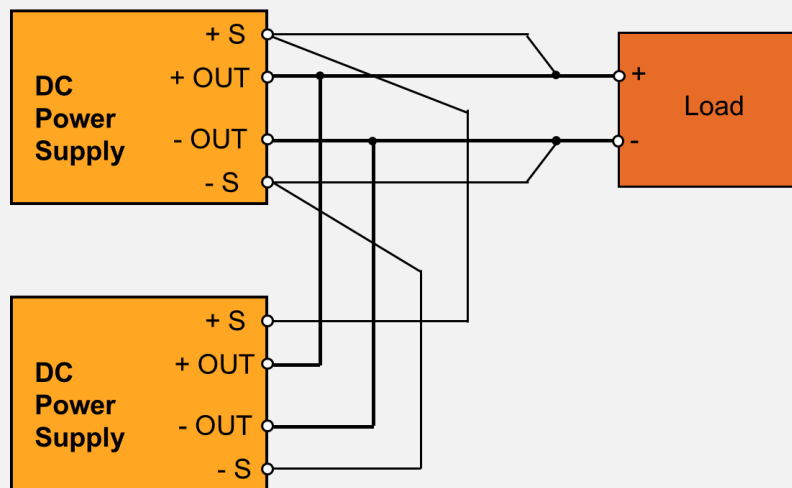

Figure 3.14 – Connecting power supplies in parallel to achieve more current output.

You should also obey the following guidelines:

- One output must operate in constant voltage (CV) mode and the other(s) in constant current (CC) mode
- The output load must draw enough current to keep the CC output(s) in CC mode
- Only connect outputs that have identical voltage and current ratings in parallel
- When you use remote sense in a parallel configuration, wire the remote sense terminals on each output in parallel and connect them to the load as shown in the diagram in the lower right of this slide
- Keep the wiring from the power supplies to the load as short as possible and twist or bundle the leads to reduce lead inductance and noise pickup. The goal is to always minimize the loop area or physical space between the + and - output leads from the power supply to the load.



You should set the voltage setting of the supply operating in CV mode slightly lower than the voltage setting of the supplies operating in CC mode. The reason for this is as follows. The supply set higher in voltage will push current into the load until it hits CC mode. After the supply reaches CC mode its output voltage will lower to the level of the other connected power supplies' voltage, and those supplies will then regulate in CV mode and contribute the remaining load current. The paralleled supplies have to end up in different operating modes (CV or CC). Otherwise, they will fight with each other for control and one will win, or they will "motorboat" the control back and forth which is not desirable.

Note: To simplify the settings for paralleled outputs, some power supplies support an advanced feature called "output grouping." Up to four identical outputs can be "grouped," enabling you to control all grouped outputs as if they were a single, higher-current output.

### Measuring Power Supply Output Current

It is surprising that, even when power supplies have the ability to accurately measure the current they output or sink, many users refuse to trust this capability and instead use additional equipment to achieve the same result. Let us examine the different options in-turn.

#### Using an external ammeter

An external ammeter can give decent results, but it is (of course) limited by the ammeter's specified accuracy (which may be worse than that of the power supply). In addition, to use the ammeter you need to break the circuit path to place the ammeter in the current path. Finally, for some high current output supplies it may be difficult to find an ammeter that can handle the current.

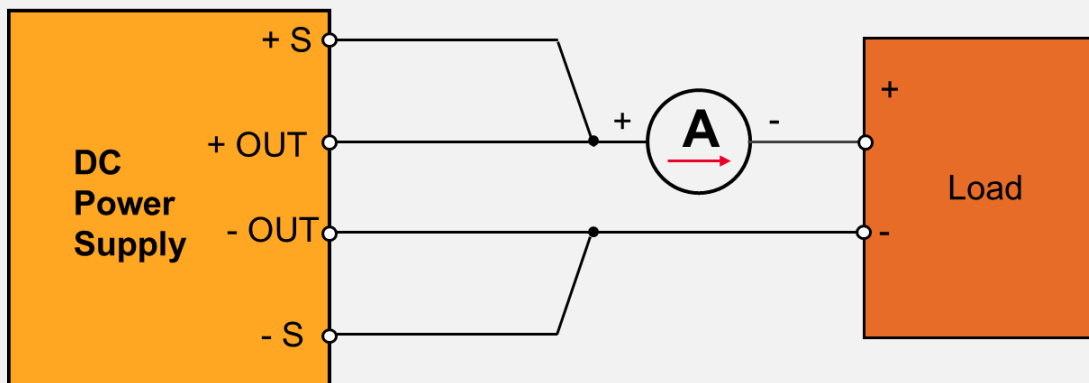

Figure 3.15 – Measuring power supply current using an external ammeter.

## Using a DMM with an external current shunt

This is more problematic than using an ammeter, as you must consider both the accuracy of the DMM and the accuracy of the resistive shunt you are using. You also need to break the circuit path just as in the case of the ammeter. There are also some other factors that can affect measurement accuracy, such as thermal EMF, improper shunt calibration and self-heating effects.

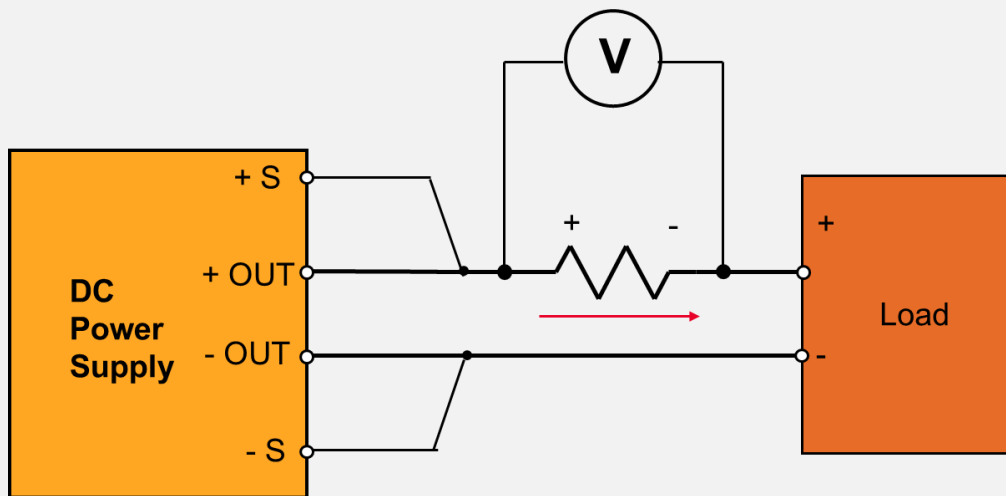

Figure 3.16 – Measuring power supply current using an external shunt and voltmeter.

## Using the DC power supply's built-in capabilities

This discussion should have helped to convince you of the advantages of using and trusting the power supply's built-in current measurement capabilities. It has the obvious advantage of not requiring you to break your circuit or add any additional connections. In addition, the accuracy is quite good as shown in the following table.

Power Supply Current Readback Accuracy	
Output level	Typical accuracy
100% of rated output	0.1% to 0.5%
10% of rated output	0.5% to 1%
1% of rated output	Approximately 10%

## Connection Considerations

### Minimizing noise

To minimize DC power supply noise you should first start by selecting a supply with low-noise specifications. As previously discussed, this does not mean that your only possible choice is a linear power supply (which are typically large and run quite hot). Modern switch-mode DC power supply technology has improved to the point where the noise on the output can be comparable to that of a linear supply.

Once you have selected a supply with satisfactory RMS and peak-to-peak output voltage noise specifications you also need to pay careful attention to the lead connections to your DUT. All connections between your supply and DUT are susceptible to noise pick-up, with common noise sources being inductive coupling, capacitive coupling, and radio frequency interference. Although there are several ways to reduce noise, the most effective method is to ensure your load and sense connections use shielded two-wire cables. However, when using shielded cables make sure to connect the shield to earth ground at only one end. Neglecting to connect the shield on either end can increase capacitive pick-up. Also, do not connect the shield to ground at both ends because ground loop currents can occur. The following figure shows a ground loop current that developed because of the difference in potential between the supply ground and the DUT ground.

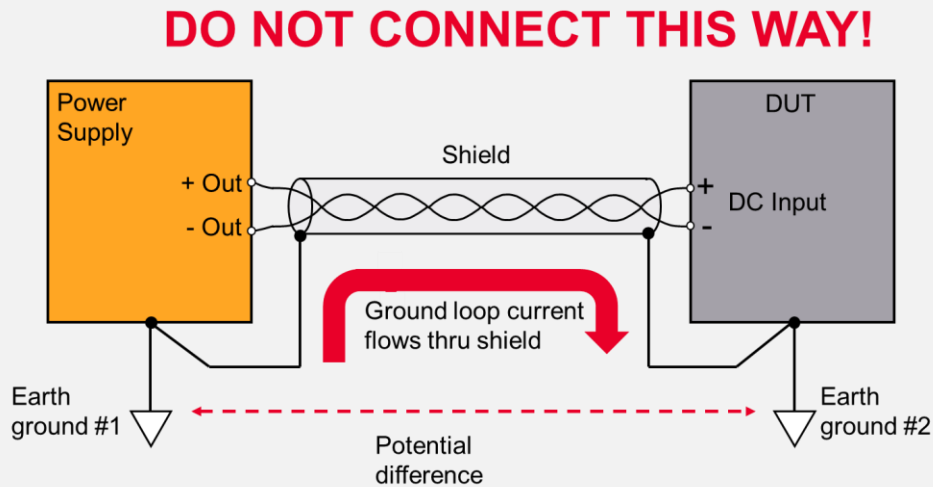

Figure 3.17 - Ground loop current caused by potential difference between the supply ground and the DUT ground.

The following figure shows an example of the proper way to connect the shield on the power supply end to earth ground.

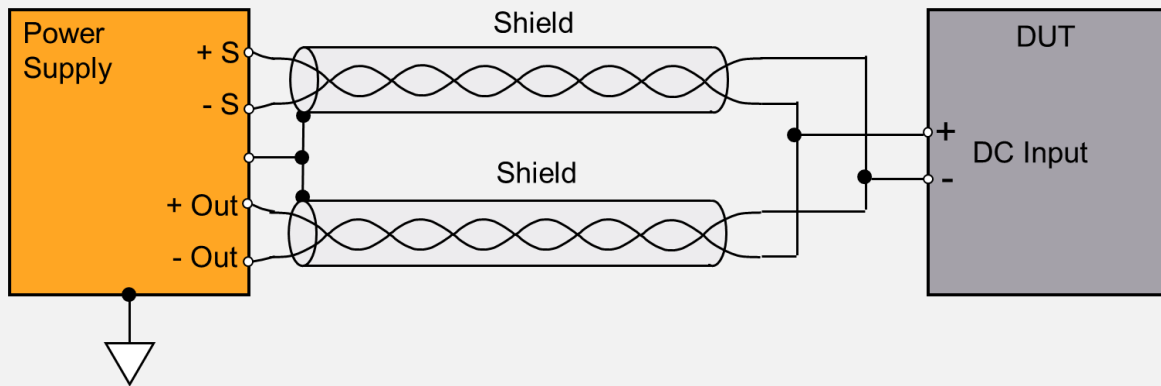

Figure 3.18 - The proper way to connect the shield on the power supply end to earth ground.

We discussed common mode noise in great detail when we discussed the relative merits of linear and switching power supplies earlier in this chapter. As a reminder, common mode noise is noise that occurs when common mode current flows from inside a power supply to earth ground and produces voltage on impedances to ground, including cable impedance. From a cabling and connection viewpoint, the best way to minimize the effect of common-mode current is to equalize the impedance to ground from the plus and minus output terminals of the power supply. You should also equalize the impedance from the DUT plus and minus input terminals to ground. To achieve this, use a common mode choke in series with the output leads and a shunt capacitor from each lead to ground.

### Output relay concerns

Although you may expect your power supply output to be completely open when you set an “output off” state, this may not be the case. Even among a single supplier’s products, the “off” output impedance can vary from power supply model to model and may depend upon the options installed in the power supply. In general, the “output off” state will typically set the output voltage and output current to zero and disable the internal power-generating circuitry. However, these settings do not guarantee that no current will flow into or out of your DUT (as would be the case if you physically disconnected the output terminals from your DUT). When the power supply output is “off” but not completely open, a number of factors could adversely affect your DUT:

- Your DUT contains a source of DC power and you have it connected directly across the power supply output.
- Your DUT contains a source of DC power and you have it connected across the output in a reverse-polarity configuration.
- Your DUT is sensitive to extra capacitive loading. – Your DUT produces a changing voltage across the power supply output.

Some power supply models have an internal output relay option that can completely disconnect the power supply output from your DUT. The relay shown in the following figure opens when you use an “output off” setting and stops all current flow to the DUT.

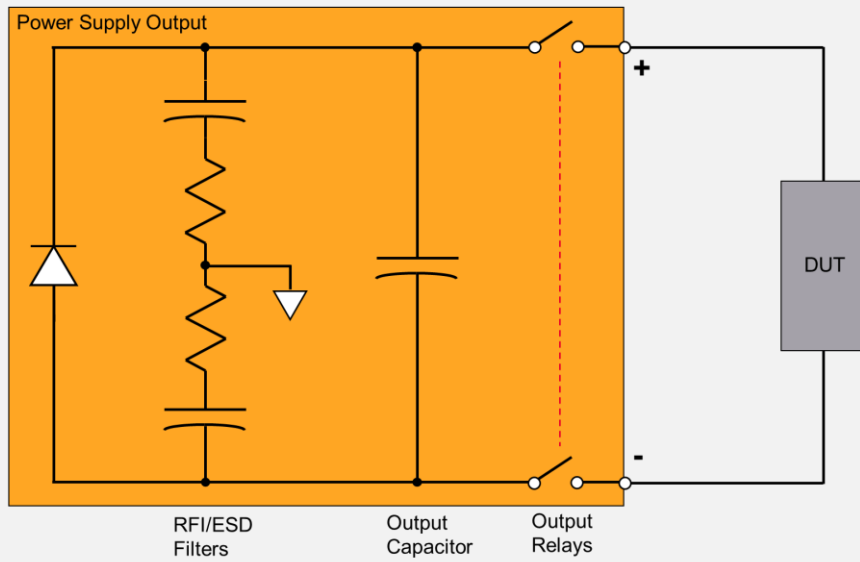

Figure 3.19 – Power supply output relay configuration with complete isolation.

However, even with a relay option installed, certain models may still have output capacitors or capacitively coupled networks connected from the output terminals to chassis ground because of the location of the relays, so your DUT will still have connections to these components as shown in the following figure.

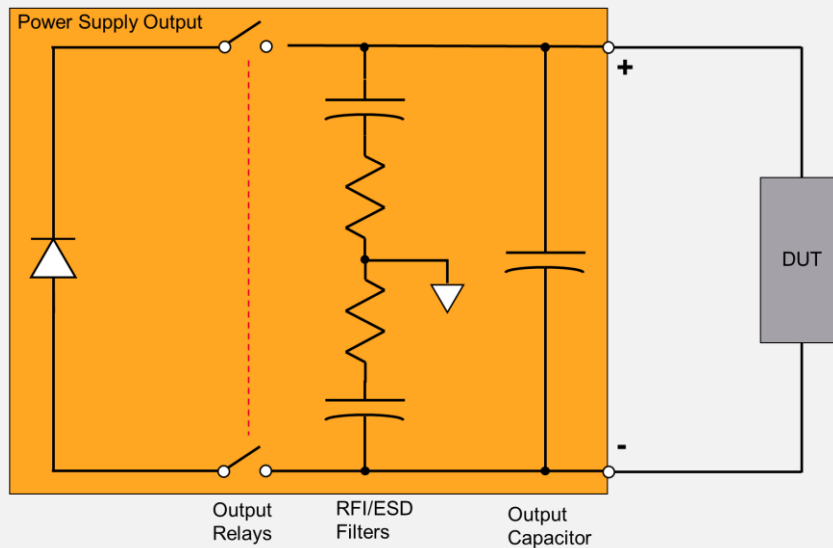

Figure 3.20 – Power supply output relay configuration where some components connect to the DUT.

## Advanced Power Supply Features

### Dynamic waveform measurement

While most power supplies can measure DUT steady-state voltage and current, some power supplies can also measure dynamic voltage and current. These supplies feature a built-in digitizer. Traditionally, engineers use digitizers for data acquisition to capture and store analog signals. Like an oscilloscope, which uses a digitizer to display the analog signal present on one of its inputs, a power supply's built-in digitizer captures the dynamic voltage and current. The following figure shows a digitizer converting an analog waveform into a set of data points. Upon a trigger, the digitizer takes measurement samples and stores them in a buffer.

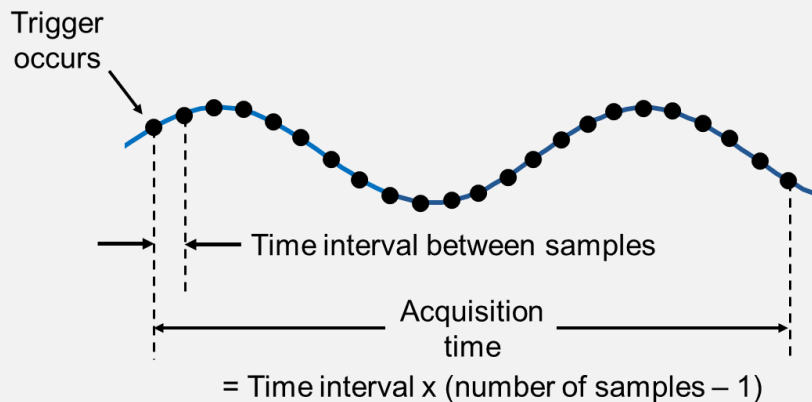

Figure 3.21 – Example of the digitization of a waveform by a power supply.

When you make a digitizing measurement, you can set two of the following three parameters:

1. Time interval – time between samples
2. Number of samples – total number of samples you want to take
3. Acquisition time – total time during which you want to take samples

Obviously, when two of these parameters are set the remaining parameter will be determined by the equation:

$$\text{Acquisition time} = \text{Time interval} \times (\text{Number of samples} - 1)$$

### Generating arbitrary waveforms

Typically, we use power supplies to bias circuits that require a constant voltage. However, more advanced applications may require a time-varying voltage (or current). Modern power supplies can easily manage both of these needs using list mode to address the time-varying applications. It is of course possible to program a PC to change the voltages on a power supply output for discrete periods of time. In this way, your program controls the transitions between voltages to allow you to test your

DUT at different volt ages. However, list mode lets you generate these voltage sequences and synchronize them to internal or external signals without tying up the computer. You specify individually programmed steps of voltage (or current), and an associated step duration. After setting the duration for each step, you trigger the list to execute directly on the power supply. You may set the power supply to

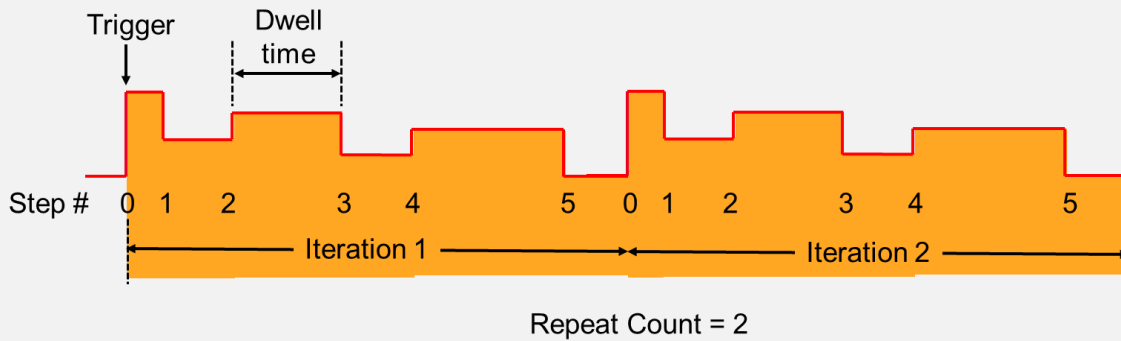

Figure 3.22 – Example of creating a time-varying waveform using list mode.

move on to the next step based on dwell times or triggers. You can program a list to repeat once, or multiple times as shown on in the following figure.

To create a list, set the following:

1. One or more voltage or current steps – defined voltage or current values
2. Dwell times – duration associated with each voltage or current step
3. Repeat count – the number of times you want the list to repeat

A good application example of using list mode is performing a voltage waveform test on automotive electronic systems. During the startup of an internal combustion engine, also known as a cold-crank, battery voltage levels drop considerably as the electric starter motor draws enormous amounts of

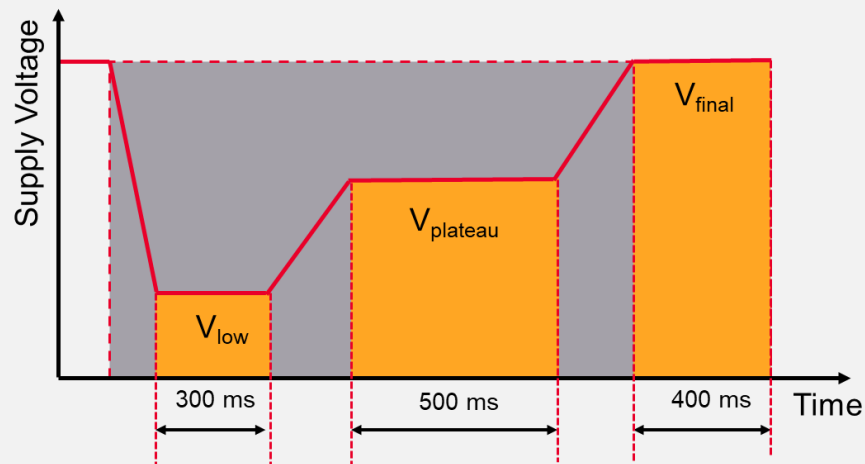

Figure 3.23 – Example using list mode to simulate a cold crank voltage profile.

current as shown in the following figure. The battery voltage then plateaus once the engine is turning and hits a final level as the electric starter turns off.

## Two Quadrant Power Supplies

What is a two-quadrant power supply?

A two-quadrant power supply can function as both a power supply and an electronic load (see Chapter 4). Basically, for all positive voltage values a two-quadrant power supply can both source and sink current. This is a very convenient capability, as it eliminates the need for a separate electronic load. In addition, a properly designed two-quadrant supply permits seamless transition between sourcing and sinking current (and vice-versa). An example of the use of a two-quadrant power supply is battery life testing (charge/discharge cycling).

Issues when operating near zero volts

Operating near zero volts is challenging for a two-quadrant power supply for the following reason. As we explained earlier in this chapter, power supplies compensate for the Ohmic drop in their supply lines using a 4-wire connection. Therefore, to maintain zero volts at the DUT the power supply actually has to be able to supply a negative voltage (which it can only do if the power supply supports four-quadrant operation). The following figure illustrates this issue.

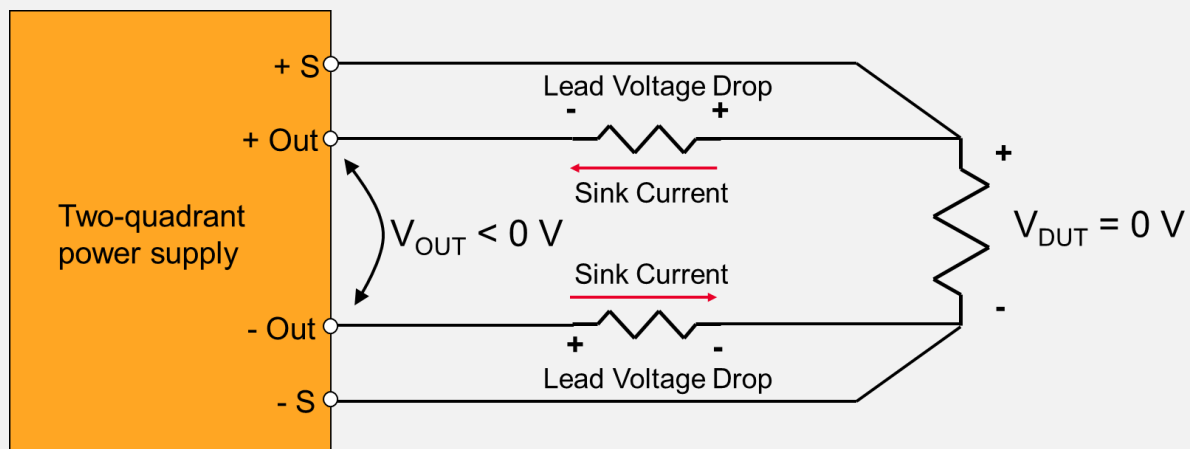

Figure 3.24 – Two-quadrant power supply voltage when sinking at zero volts.

In order to sink current when the DUT voltage is at zero volts, the power supply voltage actually has to be slightly negative. This leads many users to believe that only a four-quadrant power supply will work when sinking current at zero volts; however, this is not necessarily the case. Some two-quadrant power supply can still regulate correctly down to zero volts even when sinking current while other will not. Whether or not this is possible you can ascertain by looking at their output characteristics.

The design of some two-quadrant power supplies gives them the ability for their output voltage to go slightly negative. While the user cannot program them to a negative voltage, they will automatically



source a slightly negative voltage to sink current when the DUT load is at zero volts. You can recognize these supplies from their output characteristics. A two-quadrant power supply capable of sourcing and sinking its full output current rating even at zero volts will have a characteristic similar to that of the following.

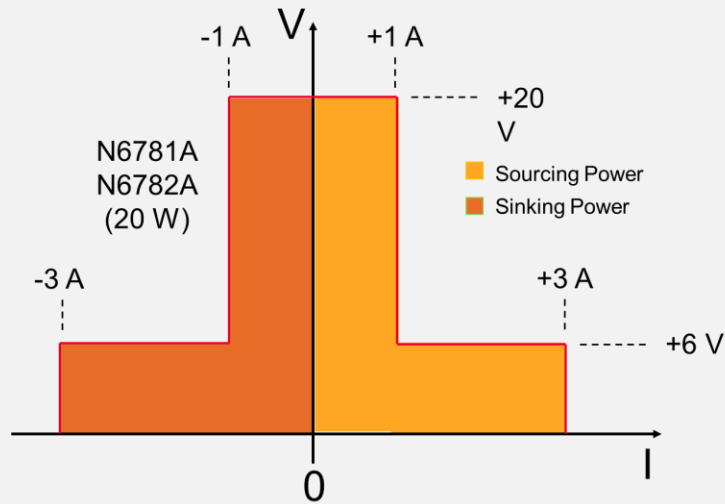

Figure 3.25 – A two-quadrant power supply characteristic capable of sinking full current at zero volts.

This example shows Keysight’s N6781A and N6782A two-quadrant power supplies, which are capable of regulating down to zero volts even when sinking full current. While this is obviously a nice feature, it does not come for free. The added design complexities of these types of two-quadrant power supplies make them inherently more expensive than conventional two-quadrant supplies.

Keysight’s N6900A and N7900A series of advanced power supplies are examples of two-quadrant power supplies that cannot sink full current at zero volts. These supplies require a minimum amount of positive voltage when sinking current, as you can see from the following output characteristic.

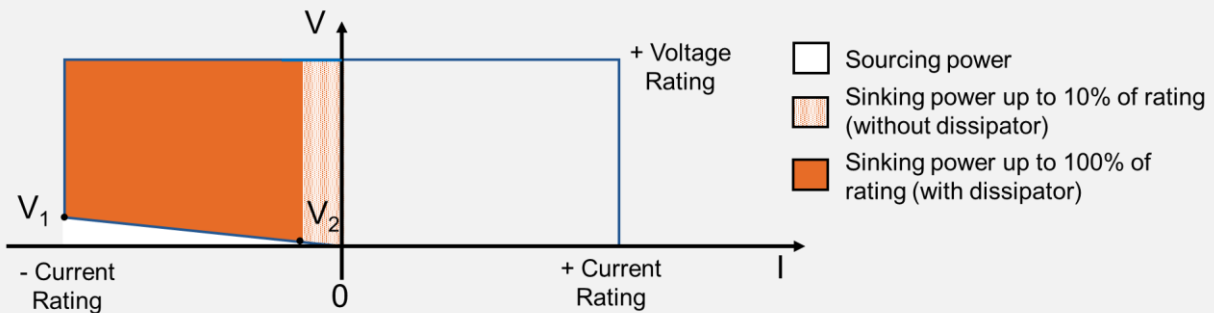

Figure 3.26 – Output characteristic for the N6900 and N7900 series of advanced power supplies.

When acting as a load, the minimum positive voltage is proportional to the amount of sink current with different characteristics and limits based on model as shown in the following table.

1 kW Models	N6950A N7950A	N6951A N7951A	N6952A N7952A	N6953A N7953A	N6954A N7954A
+ Voltage Rating	9 V	20 V	40 V	60 V	80 V
+ Current Rating	100 A	50 A	25 A	16.7 A	12.5 A
- Current Rating (with dissipator)	-100 A	-50 A	-25 A	-16.7 A	-12.5 A
V <sub>1</sub>	0.68 V	0.525 V	1.9 V	1.47 V	2 V
V <sub>2</sub>	0.068 V	0.0525 V	0.19 V	0.147 V	0.2 V
Minimum sinking resistance	6.8 mΩ	10.5 mΩ	76 mΩ	89 mΩ	160 mΩ

These two-quadrant power supplies are not able to regulate down to zero volts when sinking current because they do not have the internal negative power voltage rail that this requires.

## Regenerative Power Supplies

What is a regenerative supply?

A regenerative power supply is a sub-category of two-quadrant power supplies that can return most of the power it dissipates (when acting as a load) to the AC supply line. Regenerative power supplies possess three key advantages over conventional two-quadrant power supplies:

1. By returning most of the power they sink to the main AC line, they consume less energy than conventional two-quadrant supplies.
2. Since they are dissipating very little power when in sink mode, they require considerably less cooling than conventional two-quadrant supplies.
3. In addition, since they do not need as much cooling as traditional two-quadrant power supplies they can be more compact.

The following figure shows a typical output characteristic for a two-quadrant regenerative power supply.

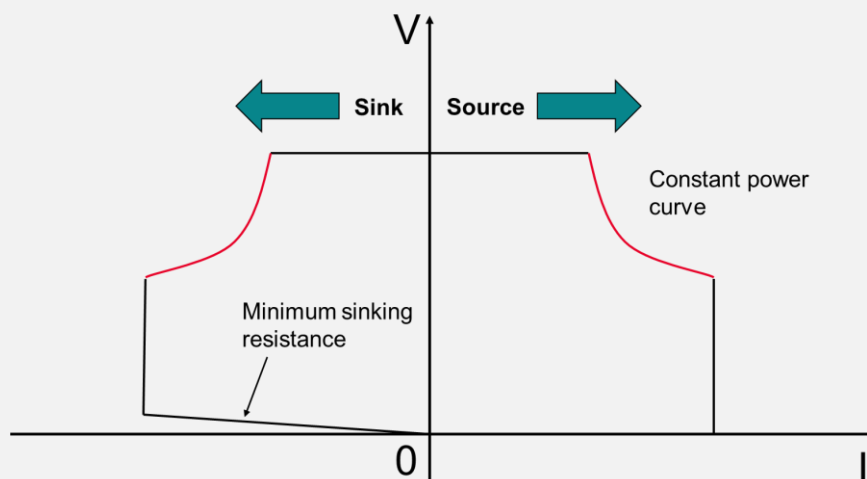

Figure 3.27 – Output characteristics of a regenerative power supply.

Keysight has a variety of regenerative power supplies with power outputs ranging from 5 kW to 20 kW. These supplies can return at least 90% of the power they sink to the electric grid. You can also easily gang them together for high power applications (for example combining three 20 kW supplies together to provide 60 kW).

## Source/Measure Units (SMUs)

### What is an SMU?

A source/measure unit or SMU (as the name implies) is capable of sourcing and measuring both voltage and current. SMUs are at least two-quadrant devices, meaning that they can both source and sink current at positive values of voltage. Many SMUs are four-quadrant devices, meaning that they can source and sink current at both positive and negative voltages. SMUs typically focus as much (or more) on measurement as they are on sourcing. SMUs also normally possess capabilities not found in standard power supplies. For example, most SMUs can make time-sampling measurements of voltage and/or current while forcing voltage or current. Such a capability is useful if (for example) you want to record the voltage on a battery over time as it experiences a constant current load. The following figure shows the conceptual circuit schematic for an SMU.

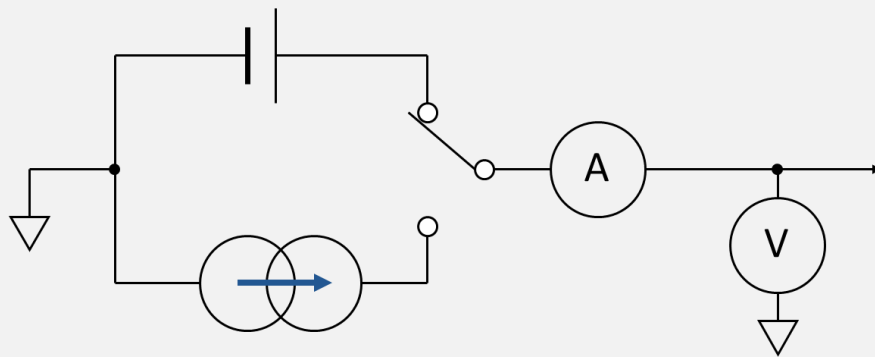

Figure 3.28 – The conceptual circuit schematic for an SMU.

As you can see, SMUs are single-ended devices with one end always tied to an internal reference point. Normally this reference point connects to the chassis ground as the previous figure shows. However, most SMUs also have the ability to disconnect the low side from the chassis ground and allow it to float. How much above or below ground the low side can float depends on the particular SMU hardware. Also, while it is obvious that you must specify whether the SMU is forcing voltage or current, most SMUs can measure both voltage and current simultaneously. While it might seem counterintuitive to measure a forced quantity, doing so can help guarantee that nothing abnormal is occurring.

### Keysight SMUs

Keysight has a wide variety of SMUs available in a number of form factors. This section will supply an overview of our different SMU families and explain their principal applications.

The N6700 Modular Power System family, which consists of the N6700C and N6705C mainframes, supports both two and four quadrant SMU modules. The following table shows a brief summary of their voltage, current and power output capabilities.

	N6781A / N6782A	N6784A	N6785A / N6786A
Maximum Voltage	20 V / 6 V	$\pm 20$ V / $\pm 6$ V	20 V / 15 V / 10 V / 6 V
Maximum Current	$\pm 1$ A / $\pm 3$ A	$\pm 1$ A / $\pm 3$ A	$\pm 4$ A / $\pm 5$ A / $\pm 6.7$ A / $\pm 8$ A
Maximum Power	20 W	20 W	80 W

A typical measurement application for the N678xA SMUs is measuring voltage or current versus time, such as monitoring the current draw of a battery powered device during various operation modes. The N678xA SMUs can datalog up to 90 minutes of data at 50 kSa/s using N6700 internal memory (or infinite time if using an external PC). The N678xA SMU also possess seamless measurement ranging, allowing them to make fast dynamic measurements from 100 nanoamps up to 3 Amps.

Seamless measurement ranging is very important when measuring the current draw of IoT devices for the following reasons. Battery powered mobile devices alternate between several different modes during their operation (i.e. active, idle and sleep), which means that the current they draw at any point in time can vary from milliamps to nanoamps as shown in the following figure.

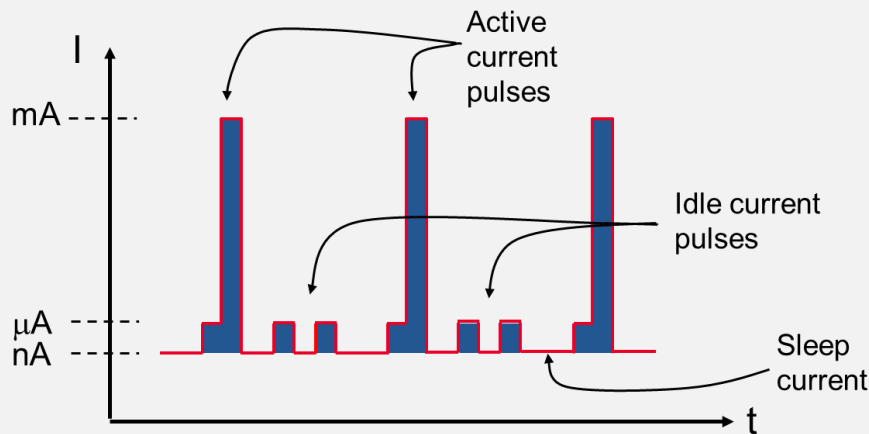

Figure 3.29 – A typical IoT device operates in several different states with widely different current requirements during each state.

This makes current measurement very difficult for the following reasons:

- Measurement equipment must have an extremely wide dynamic range
- Device modes change very rapidly
- The current draw changes randomly depending on what tasks the device is doing
- Traditional test tools cannot make these difficult measurements due to ranging limitations

In order to understand the importance of seamless measurement ranging we first need to explain what measurement ranges are and how measurement ranging works. Measurement ranging is intimately interrelated with measurement accuracy and resolution, so before proceeding it is important to understand why SMUs have a range setting in the first place. The SMU circuitry has to switch in and out (using relays) different resistor values in order to handle the maximum expected current or voltage value based upon the measurement range specified by the user. The following figure shows an example of this circuitry.

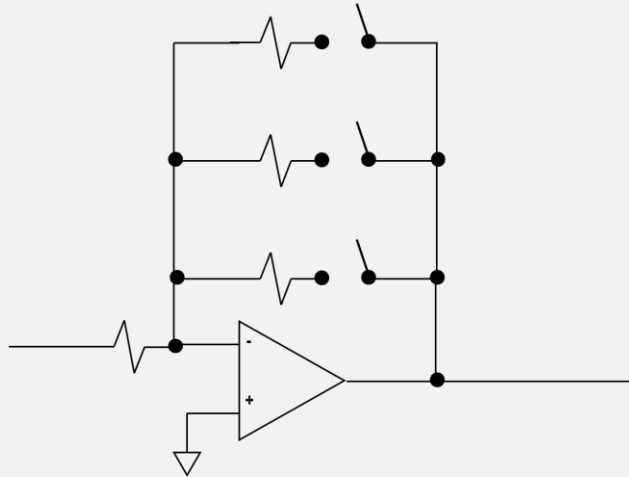

Figure 3.30 – SMU ranging requires that resistors of different values switch in and out of the circuit depending upon which particular range you are in.

Selecting one or more resistors via these relay switches places the SMU into a given measurement range. Obviously, it takes some time to switch these relays and move from one range to the next. While it would be possible to always have the SMU start at the highest possible measurement range and work its way down to the lowest measurement range that contained the quantity under measurement, this would result in extremely slow measurements. By allowing flexibility as to how you can select a measurement range, the user gains the ability to trade off measurement speed versus accuracy.

There is no hard and fast rule to specify the measurement resolution achievable within a given measurement range. The primary determining factor is the number of bits in the SMU analog-to-digital converter (ADC). However, the actual measurement resolution achievable has to consider other factors such as noise, drift, etc. This introduces a stochastic element to the measurement that requires averaging. The net result is that in most cases the minimum measurement resolution is 4-5 decades below the measurement range. Even if the actual measured value is more than 4-5 decades below the selected measurement range, the instrument will still return a result (albeit with reduced measurement resolution). However, if you try to measure a current or voltage that exceeds the specified fixed measurement range then you will get a measurement error. Therefore, finding the optimal fixed measurement range is always a balancing act between selecting a range low enough to provide sufficient measurement resolution and high enough to always contain the quantity under measurement.

This explanation of measurement ranging should have made clear the key difficulty faced when trying to measurement devices with currents that vary rapidly across many orders of magnitude. The SMUs cannot change ranges rapidly enough to keep up with the device state changes, so you lose current measurement accuracy and resolution. However, this is where Keysight SMUs have a major advantage: seamless measurement ranging. Seamless measurement ranging is a patented technique that allows the SMU to change ranges rapidly with no delay or data loss as shown in the following figure.

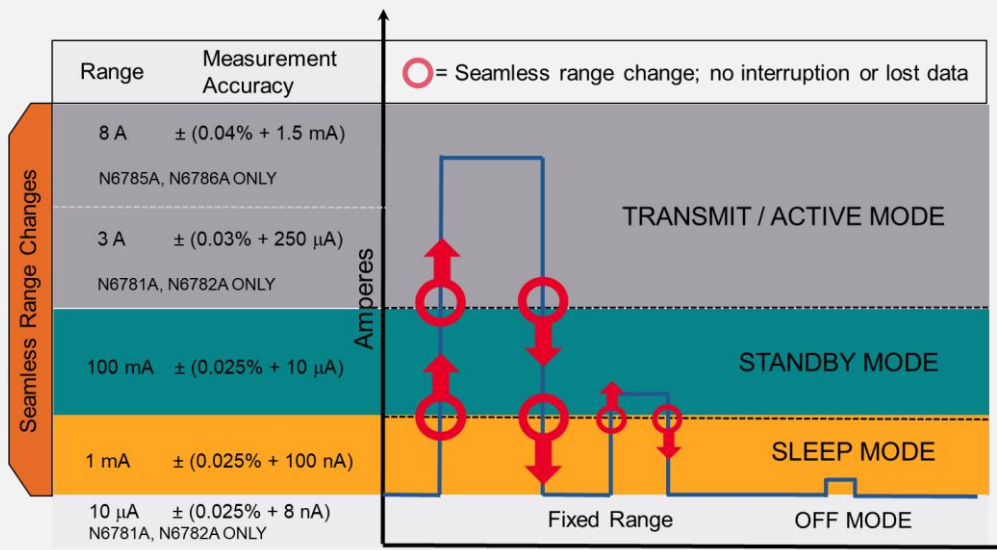

Figure 3.31 – Graphic showing how seamless measurement ranging can prevent data loss as the instrument moves between different measurement ranges.

The following screen captures dramatically demonstrates the difference in measurement performance. It compares measurement measurements made using fixed ranging with those made using seamless measurement ranging.

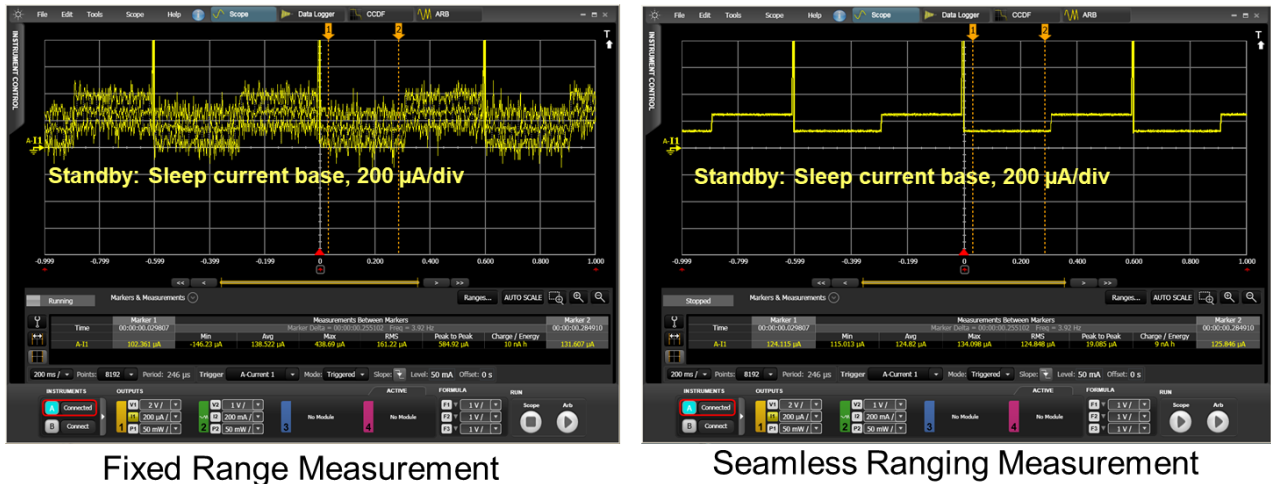

Figure 3.32 – Comparing the results of measuring cell phone current draw using fixed measurement ranging with those obtained using seamless measurement ranging.

The B2900 Series of SMUs are standalone benchtop instruments with a focus on device and material characterization. All of the B2900 SMUs support four quadrant operation and have a front panel interface. In addition, the higher performance models can achieve measurement resolution down to 10 femtoamps. The “BL” models are single-channel, and the “B” models are available in both one and two channel versions. The following table summarizes the key specifications of these SMUs.

	B2901BL	B2910BL	B2901B/ B2902B	B2911B/ B2912B
Maximum Voltage (DC)	21 V	210 V	210 V	210 V
Maximum Current (DC)	1.5 A	1.5 A	3 A	3 A
Maximum Current (Pulsed)	---	---	10.5 A	10.5 A
Current Measurement Resolution	1 pA	10 fA	100 fA	10 fA



Figure 3.33 – Front view of the B2900B SMU.

Keysight also has a family of PXIe SMUs that support many different application needs. The following table summarizing the capabilities of these SMUs.

	M9111A	M9601A	M9602A/03A	M9614A/15A
Quadrants	2	4	4	4
Channels per Card	1	1	1	5
Maximum Voltage (DC)	13 V/6 V	± 210 V	± 60 V	± 30 V
Maximum Current (DC)	± 1 A/± 3 A	± 315 mA	± 3.5 A	± 500 mA
Maximum Current (Pulsed)	NA	± 315 mA	± 10.5 A	± 500 mA
Minimum. Pulse Width	NA	20 μs	10 μs	100 μs
Maximum Sample Rate	200 kSa/s	1.25 MSa/s	15 MSa/s	500 kSa/s
Current Meas. Resolution	1.4 nA	10 fA	100 fA	10 pA

It is important to point out that the M9111A SMU design focuses on applications such as battery drain analysis, whereas the other PXIe SMUs are more focused on device and material characterization. The M9111A also has essentially two output voltage/current ranges, whereas the other PXIe SMUs have multiple output voltage/current ranges (they cannot simultaneously output the maximum voltages and currents shown in the table).



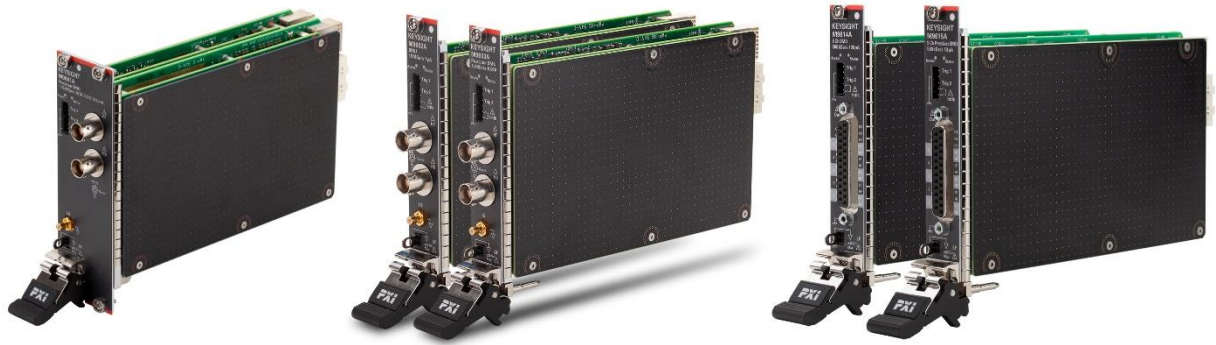

Figure 3.34 – The M9601A, M9602A/03A and M9614A/15A PXIe SMUs.

## Chapter 4 – Electronic Loads

### Electronic Load Basics

What is an electronic load?

In situations where you need a purely resistive load and you do not need closed loop control, you can use a fixed value power resistor. However, a fixed value resistor presents many limitations. It is not adequate for loading and testing power sources that have complex testing requirements. Such tasks require sophisticated electronic load features to validate the various states of operation. In addition, adapting to changes with fixed resistors is a time-consuming task that requires many resistors, switching matrixes, and the appropriate control software. Also, there is no way to control or limit the voltage or the current that the load consumes. The user needs to handle critical safety and device protection concerns in order to avoid any potential damage to the device.

Why use a load rather than a resistor?

An electronic load offers higher flexibility than a simple resistor by allowing you to sink various levels of power profiles in multiple modes. The most common operating modes of an electronic load are constant current (CC), constant voltage (CV), constant resistance (CR), and constant power (CP). The electronic load emulates various scenarios and actual devices that connect to your power source. An electronic load is an effective solution to test devices rather than using a fixed value resistor. A fixed resistor makes it difficult to automate and to emulate the dynamic behavior of a real device. It also makes it difficult to adapt to changes in test requirements. The following figure shows the polarity convention and input characteristics of an electronic load.

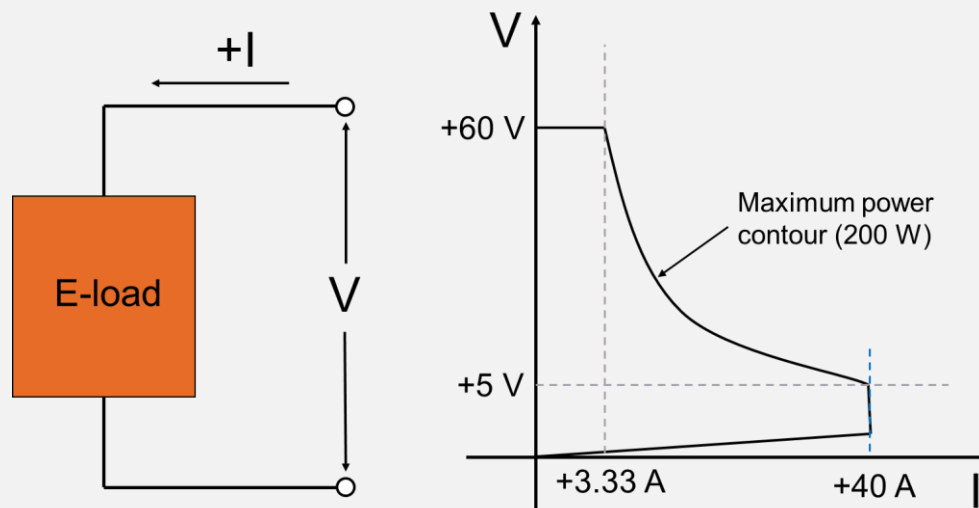

Figure 4.01 – The polarity convention and input characteristics of an electronic load.

Most electronic loads specify a maximum power level they can absorb, and in this example the maximum power that the load can absorb is 200 Watts. The user can operate the load only within the voltage and current combinations defined by the maximum power contour. For example, it would not be possible for a user to sink 20 A from a 48 V test device using this load even though both values are within the load's operating limits since the total power (960 W) is greater than the load maximum power dissipation limit of 200 W.

## What are some typical E-load applications?

The following are typical applications showing the use of electronic loads across various industries.

- **Power converter and inverter testing:** This is a fast way to test DC-DC and AC/DC converters. The electronic load helps to simulate the power-on process of the device. You can test the minimum and maximum input turn-on voltage level with different load levels. You can carry out ripple, noise, load/line regulation, over voltage, and current protection tests with the electronic load.
- **Uninterruptible power supply (UPS):** This is a complete test that requires an AC source, DC source, DC load, and AC load. The DC load uses the load bank to test the backup battery and charger within the UPS. An AC load tests the entire UPS system. A load bank test indicates the UPS's ability to provide the necessary power, voltage stability, and efficiency of control systems under varying load conditions.
- **Batteries and fuel cells:** Use constant loading to reduce the test time in comparison to resistor load banks. To test the capacity, use the CP mode to provide a consistent power drain as the battery voltage drops over time. The electronic load's capability to program different load profiles with a fast transition enables profile testing for battery charge and discharge cycles.
- **Solar panels:** This is a good solution for high-power photo voltaic testing as solar panels can sink high current at a lower cost. Use the CV mode to capture the I-V curve and incremental voltages to measure the current. With portable devices, program the e-load to simulate various device power states such as sleep, power conservation, and full power modes for a power consumption test.
- **Portable devices:** Use the electronic load to simulate various device power states such as sleep, power conservation, and full power modes to test power consumption.

## DC Electronic Load Operation Modes

Unlike DC power supplies, where the operation mode is determined by the interaction of the set condition with the load and crossover resistances, in the case of electronic loads you can specify the operation mode. Electronic loads can operate in one of five modes.

### Constant Current (CC) Mode

Constant current (CC) is the most frequent use mode for electronic loads. In constant current mode the load will sink the programmed current independently from the output voltage (which the voltage source typically connected to it controls). For example, suppose you have a 3 V battery and would like to discharge it with a constant current of 1 A as shown in the following figure. The operating point is the (voltage and current) setpoint where the battery output voltage intersects the programmed constant current load line of the electronic load.

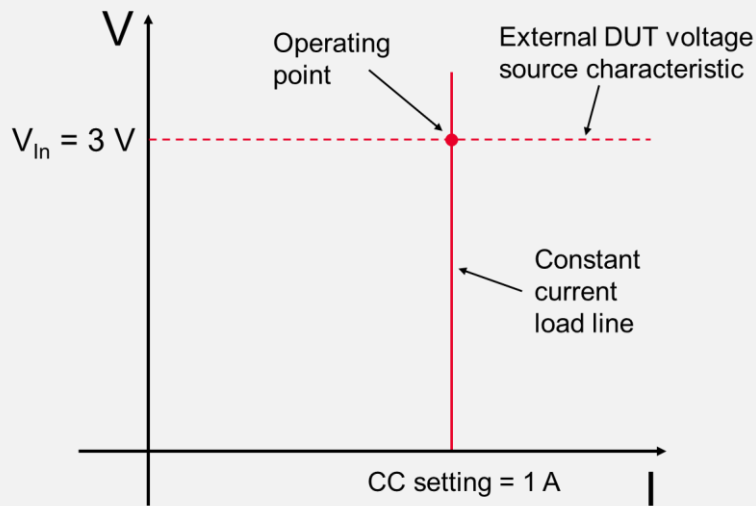

Figure 4.02 – Electronic load IV diagram when operating in constant current mode.

The following figure shows how the electronic load’s internal circuitry operates to regulate the current when connected to a voltage source.

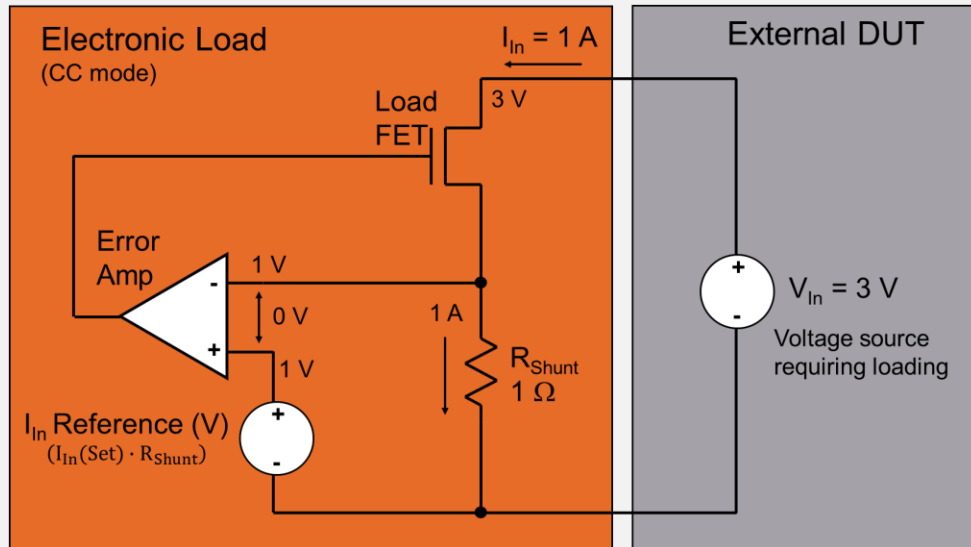

Figure 4.03 – Electronic load circuit in constant current operation.

As you can see, the electronic load uses power transistors (usually multiple FETs in parallel) to regulate the current flowing into the load. This works quite well, although the FETs do create some issues when the source voltage drops below about 0.4 V (more about this later). In this example we have a 3 V voltage source on our DUT and we have programmed the electronic load to sink a constant 1 A. A shunt

resistor (in this example  $1\ \Omega$ ) monitors the current flowing into the load. The voltage drop (which is proportional to  $I \cdot R_{\text{shunt}}$ ) feeds into an error amplifier, and the error amplifier compares the voltage drop on the current shunt against the reference programmed value (in this example  $1\ \text{A} \cdot 1\ \Omega = 1\ \text{V}$ ). The amplifier output signal regulates the FET resistance and electronic load's input current. This feedback configuration allows the load to dynamically change the resistance and maintain the programmed current independent of voltage changes in the sourcing device.

The use of FETs in electronic loads does create issues when sinking current from DUTs at low voltage. The reason is that the IV characteristics of FETs require a minimum drain to source voltage in order to remain in saturation (around 3 V for power FETs), and at low drain to source voltage the FETs operate in their linear region and they cannot sink full current. The following figure illustrates the minimum voltage as a function of the programmable sink current for a 200 W module with a programmable short resistance of  $40\ \text{m}\Omega$ .

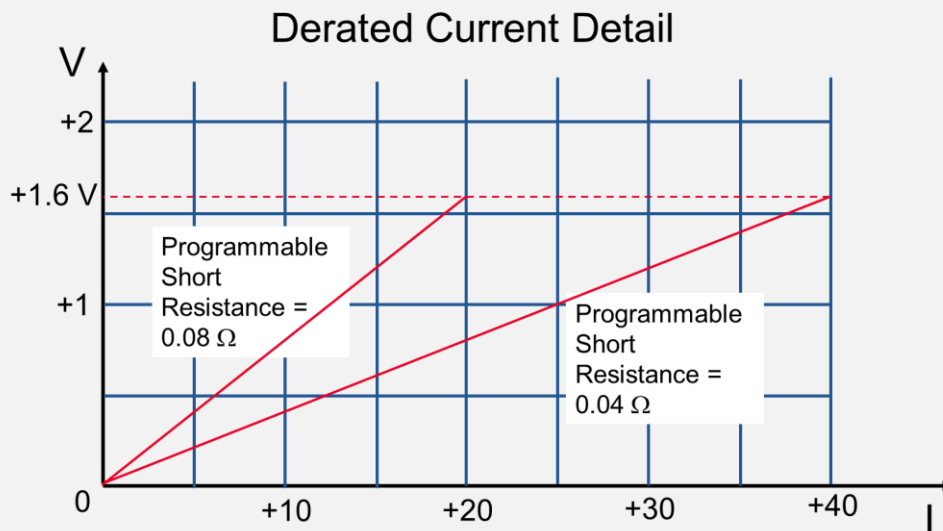

Figure 4.04 – Minimum output voltage where the load sinks the full-scale programmed current.

### Constant Voltage (CV) Mode

In constant voltage (CV) mode the electronic load sets a fixed programmable voltage across its terminals independently from the input current. In CV mode the current source connected to the load (for example, a current charging circuit or an LED current driver) determines the current. The load adjusts its resistance dynamically to attain the programmed voltage at any current established by the current source under test. Testing a battery charger operating in constant current mode is an example of how you would use a load in CV mode. You can use the load as a battery sinking current to test the behavior of the charging circuit at various battery voltages corresponding to a specific state of charge. For example, say you have a constant current charger sourcing  $0.5\ \text{A}$  and need to load it with a constant voltage of  $3.8\ \text{V}$  to emulate the charging of a lithium ion battery. The operating point is the setpoint where the current source level intersects the programmed constant voltage load line of the electronic load as shown in the following figure.

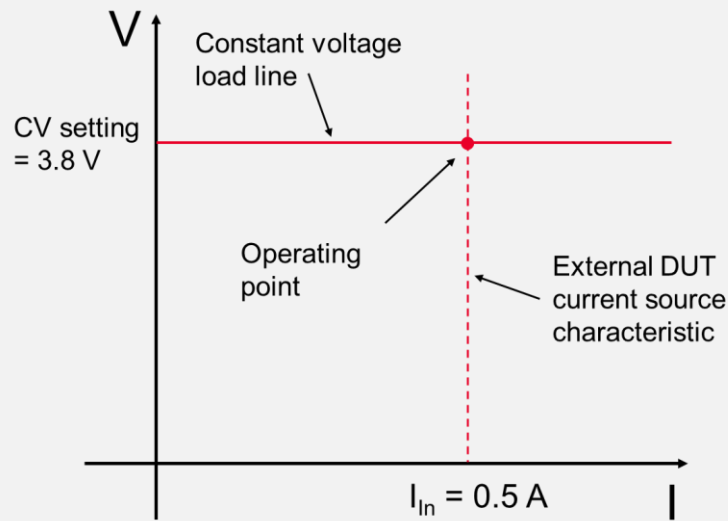

Figure 4.05 – Electronic load IV diagram when operating in constant voltage mode.

The following figure shows how the electronic load’s internal circuitry operates to regulate the voltage when connected to a current source.

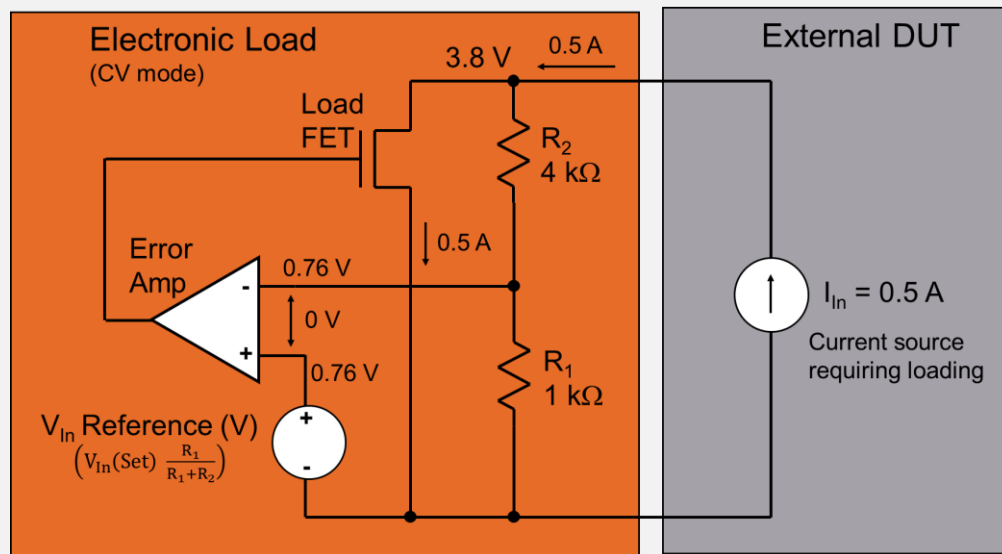

Figure 4.06 – Electronic load circuit in constant voltage operation.

Users operate the electronic load in CV mode to typically test and load a current source device – for example, a current charging circuit. The electronic load modulates its resistance to reach the programmed voltage. The load monitors the input voltage through a voltage divider. The error amplifier compares the potential of the voltage divider (proportional to the terminal voltage) against a reference

voltage (proportional to the programmed value). If the measured voltage is higher than the reference voltage, the amplifier activates the FET proportionally to decrease its resistance to match the programmed voltage. This feedback configuration allows the load to dynamically change its resistance and maintain the programmed voltage regardless of the current variation of the sourcing device. The load adjusts its terminal potential for voltages and current within its range up to the maximum voltage achievable by the sourcing device. The load regulates its terminal voltage at the programmed value if the input current remains within the current limit setting. A CV status flag indicates the output current is within the limit settings. When the input current reaches the current limit, the load no longer operates in CV mode and the input voltage does not remain constant. The electronic load now regulates the input current at its current limit setting. A negative current limit status flag is set to indicate that it has reached a current limit. If the voltage exceeds the allowable voltage or maximum power contour for the specified current, the overvoltage protection trips and the load input turns off.

### Constant Resistance (CR) Mode

In constant resistance (CR) mode, the load acts as a fixed programmable power resistor. An electronic load's CR mode is well-suited for loading a power source that is either a voltage or current source. When the load connects to a voltage source it sinks a current equal to the source potential divided by the programmed resistance value. When the load connects to a current source, its terminal voltage is equal to the imposed current multiplied by the programmed resistance value. The following figure shows the I-V diagram of an electronic load in CR mode when loading a voltage or current source. A 5 Ω load on a 3 V voltage source will result in a 0.6 A sink current. Alternatively, the same load on a 0.6 A current source results in a 3 V load voltage.

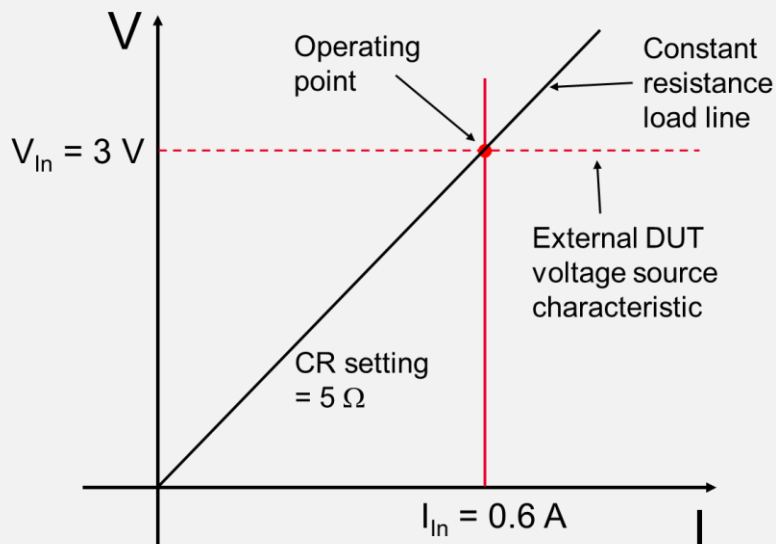

Figure 4.07 – Electronic load IV diagram when operating in constant resistance mode.

The following figure shows how the electronic load's internal circuitry operates to regulate the resistance when connected to a voltage source.

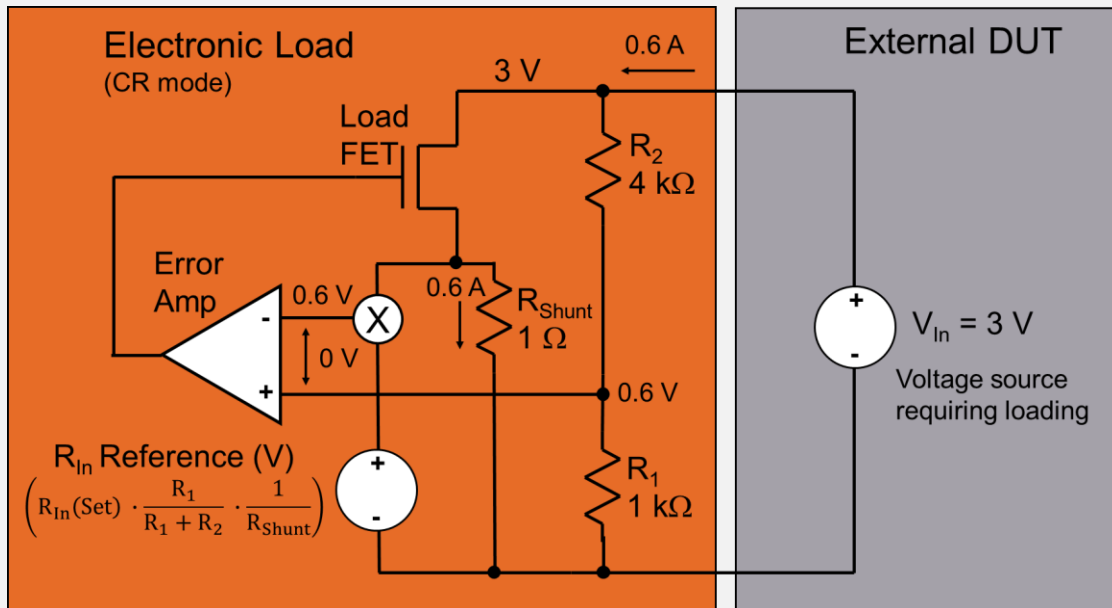

Figure 4.08 – Electronic load circuit in constant resistance operation.

In this example we are loading a 3 V voltage source with a 5 Ω power resistor. The load measures both voltage and current to adjust the FET resistance and keep the ratio between voltage and current at 5. The circuit uses a voltage divider to measure the voltage source, while a shunt resistor measures the current. The error amplifier compares the input voltage against the input current (voltage drop on the shunt times the programmed resistance) to regulate the load input at a constant resistance value. The current sensing is 1 V per Amp (1 Ω shunt resistor) and the voltage sensing is 0.2 V per Volt (1:5 voltage divider). The feedback amplifier has zero differential voltage across its terminals for an input current of 0.6 A, thus creating an input resistance of 5 Ω (3 V / 0.6 A).

If we program the load to emulate a 10 Ω resistive load on the same 3 V voltage source this would result in a 0.3 A current flowing into the load. The voltage drop across the shunt would then be 0.3 V. A multiplication factor of 2 is now necessary to achieve the same 1 V voltage drop across the feedback amplifier. The R-in reference value that you program (10 × 1/5 = 2) determines the multiplying factor. In CR mode you can even change the programmed resistance dynamically (i.e. while the power supply is on) to any value within the load range.

### Constant Power (CP) Mode

In constant power mode, the load module absorbs a constant power out of the DUT. It regulates the power drawn according to the programmed power value. The DUT can be either a voltage or current source. When testing a voltage source in CP mode, the load regulates the sink current to absorb the programmed power level. When testing a current source in CP mode the load regulates its terminal



voltage to absorb the programmed power level. The following figure shows the I-V diagram when loading a voltage source in CP mode. Loading a 5 V voltage source with 1 W constant power result in a 0.2 A sink current. In contrast, loading a 0.2 A current source with the same constant power results in a 5 V load voltage.

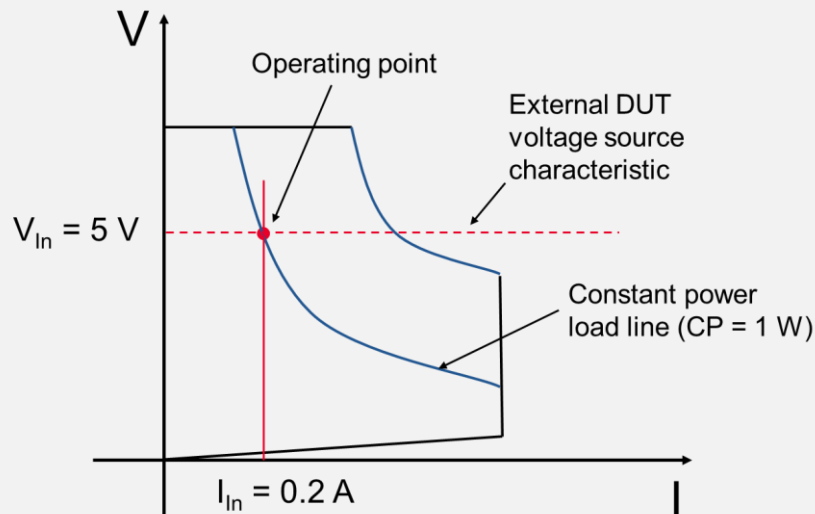

Figure 4.09 – Electronic load IV diagram in constant power operation.

Discharging a battery with constant power to obtain battery life information is one example of when you would want to use an electronic load in CP mode. The load discharges the battery with constant power and emulates the behavior of a DC-DC converter.

The following figure shows the operation of the load in CP mode. For example, if you have a 5 V battery and want to discharge it with a fixed constant power of 1 W to emulate the behavior of a DC-to-DC converter. The load in CP mode needs to measure both voltage and current to adjust the FET resistance to maintain a constant power of 1 W.

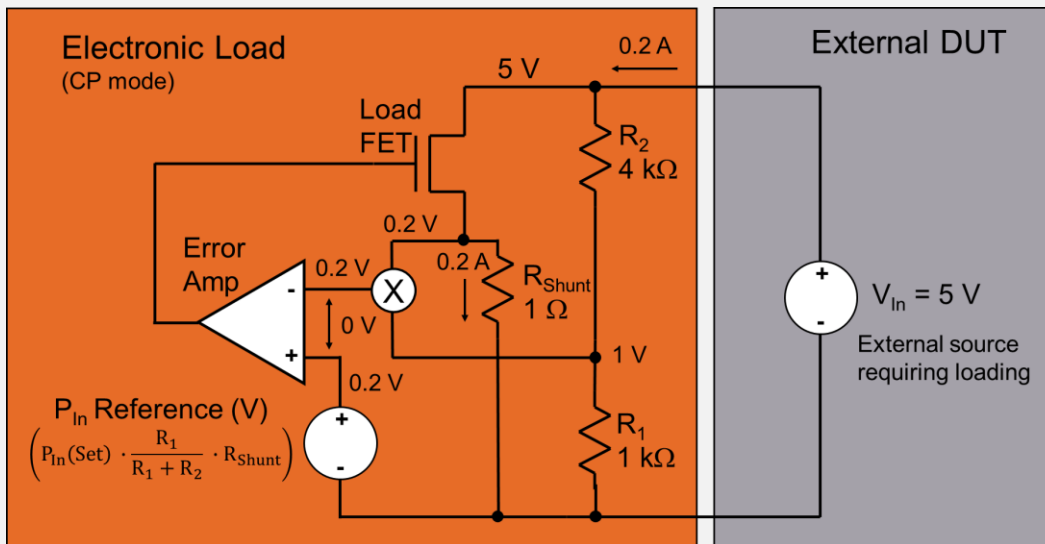

Figure 4.10 – Electronic load circuit in constant power operation.

The load monitors the input voltage through a voltage divider, while the shunt resistor measures the current. The load measures power consumption by multiplying both voltage and current (voltage drop on the shunt). The multiplication result feeds into the error amplifier. The amplifier compares the input power against the reference power value. The amplifier output signal regulates the FET conductance that controls the current flowing into the load. If the power measurement is lower than the reference power, the amplifier activates the FET proportionally. The FET increases its conductance (current flowing into the load) to match the power reference power level. The feedback configuration allows the load to dynamically change its resistance/conductance to adjust the sink current. It maintains the same power consumption level regardless of the voltage variations of the sourcing device. The source voltage and the load minimum programmable short resistance limit the maximum power the load can consume at low voltages.

Discharging a battery with constant power gives you battery life information. It allows you to understand how the DC-to-DC converter discharges the battery in similar conditions. A battery voltage usually decreases during discharge. The load in CP mode sinks additional current to keep the power consumption constant. For example, to discharge the 5 V battery down to 4 V in 1 W CP mode results in an initial discharge current of 0.2 A. When the battery voltage decreases to 4 V the discharge current increases up to 0.25 A.

### Unregulated (UNR) Mode

If the electronic load is not regulating any of the above parameters then it is operating in unregulated mode. This condition is common if the load does not have a source connected to it. When in unregulated mode, the electronic load has an unpredictable operating point.

## The Effect of FETs on Load Behavior

The previous discussions should have made the following point clear, but it is still worth repeating. Electronic loads do not use mechanical relays to control whether they are in a short or open state. They use solid state circuitry (i.e. Field Effect Transistors or FETs). All FETs have some innate, non-zero resistance when in their “on” state, so electronic loads place several of them in parallel to lower the overall value of the “short” input resistance. Even so, the input resistance in this case is not zero and typically ranges from 10 milliohms to 100 milliohms. It is also true that when the FETs are their “off” state they do not exhibit infinite resistance. Here actually the value of the input resistance can vary quite a bit, from 20 kilo-Ohms up to 500 kilo-Ohms.

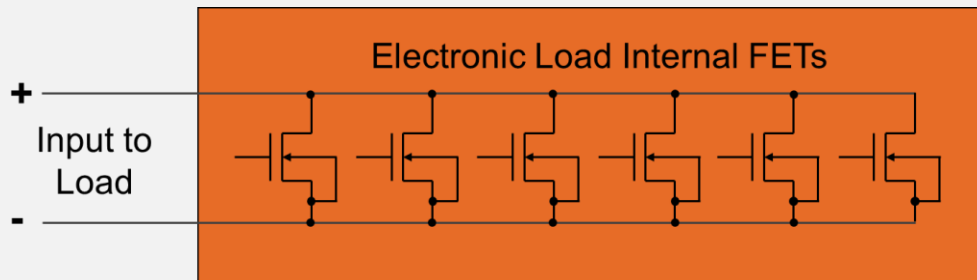

Figure 4.11 – Illustration showing how electronic loads place FETs in parallel to reduce “ON” state resistance.

Because electronic loads use power FETs in their output circuitry, there are some limitations on electronic load performance at low voltage (usually below 3 V). FETs require a minimum level of drain to source voltage to be in saturation and sink full current. For low values of drain to source voltage the FETs are operating in their linear region and they cannot sink full current. As a result, for low values of voltage some slew rate limitations apply. Check the data sheet to understand the limitations of your load.

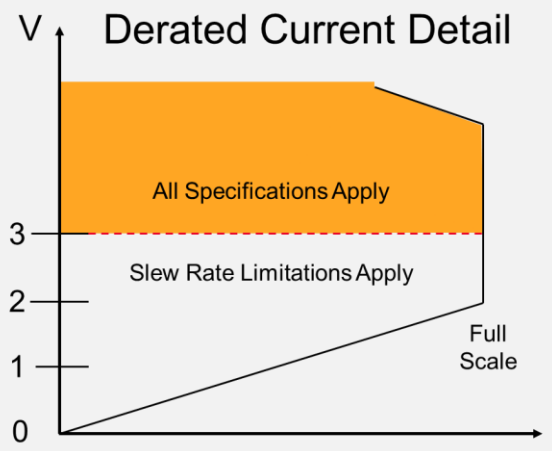

Figure 4.12 – Graph showing typical derated current graph of an electronic load.

## Overcoming low input limitations

There are some ways to work around this limitation. A feasible solution to the low voltage dilemma is to insert an auxiliary boost power supply in series with the electronic load and the power supply under test as shown in the following figure.

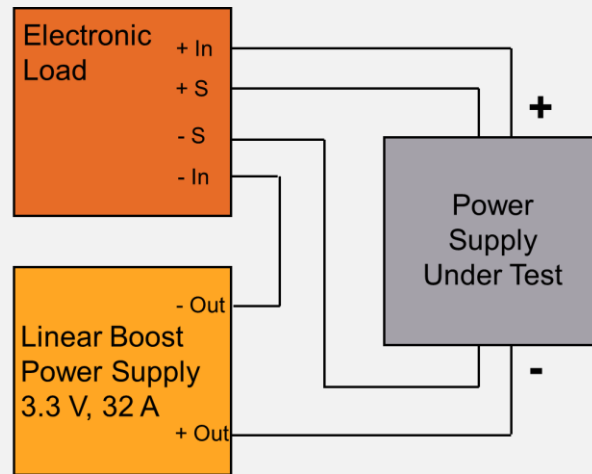

Figure 4.13 – Using a linear boost power supply to overcome electronic load low-voltage limitations.

To operate correctly in constant voltage mode, the electronic load must have its remote voltage sense leads connected across the power supply under test. The auxiliary supply can be a low-cost fixed output 3 V to 5 V power supply, but it must have a current rating at least as high as the maximum peak load current needed. While this configuration can compensate for the load minimum voltage requirement and voltage drop in the power leads, it does have some disadvantages.

1. Any current noise from the auxiliary boost supply will affect noise measurements made on the power supply under test. You can minimize this by selecting a supply with suitably low noise specifications.
2. The electronic load now has to dissipate the power from both the power supply under test and the boost supply. Therefore, a higher power load may be necessary if the original load was operating at full rated power. For example, if you want to test a 300 Watt power supply, then a 300 Watt load would not have enough capability to dissipate the power generated by both supplies. You need to select an electronic load capable of dissipating the power from both supplies.
3. The possibility exists that the boost supply could reverse bias the power supply under test as the voltage across the load decreases. This can occur, for example, when the power supply under test can no longer maintain its output voltage because it is in overcurrent protection mode. To protect against potential reverse biasing of the power supply under test you should add a special detection circuit into the electronic load as described below.

## Zero volt load

Keysight can supply zero volt load solutions, and standard models in the N3300A family support this capability. A reverse protection circuit is present to protect the power supply under test when used with an auxiliary boost power supply. The built-in reverse protection circuitry utilizes the voltage sense capability of the electronic load to measure the voltage across the power supply under test as shown in Figure 4.13. The load uses the voltage information from the sense leads to limit the current in the circuit and prevent the power supply under test from becoming reversed biased. You can use this solution with any suitable boost supply. However, it is important to understand that using a boost supply does reduce the total power that the electronic load can draw from the DUT. You can calculate the total power available using the following formula:

$$P_{Available} = P_{Load} - (I_L \cdot V_{Aux})$$

## Combining Loads in Parallel

### Never combine electronic loads in series

You may have noticed that the title of this section does not mention anything about combining electronic loads in series (which we discussed when talking about power supplies). The reason for this is simple: You should never combine electronic loads in series. The reason for this restriction is that putting electronic loads in series can potentially expose one of the load inputs to a voltage beyond its capabilities that could result in damage to the load. Assumedly you are putting loads in series because a single load does not have a high enough voltage rating to handle the voltage of your DC power source. However, since one of the load inputs could become a low impedance (nearly a short circuit) during test, all of the voltage from your DC source could appear across the other load input in series. There are several scenarios that can result in this destructive situation. To understand these scenarios, you first have to understand how an electronic load works. As we discussed earlier, loads work by controlling the conduction of FETs across their input terminals. They achieve this control using a feedback loop to adjust a measured level (such as the input current) so that it equals a reference level (such as the set current). When you put multiple electronic loads in series to accommodate higher voltage, one problem scenario occurs when you set both loads to operate in CC mode as shown in the following figure.

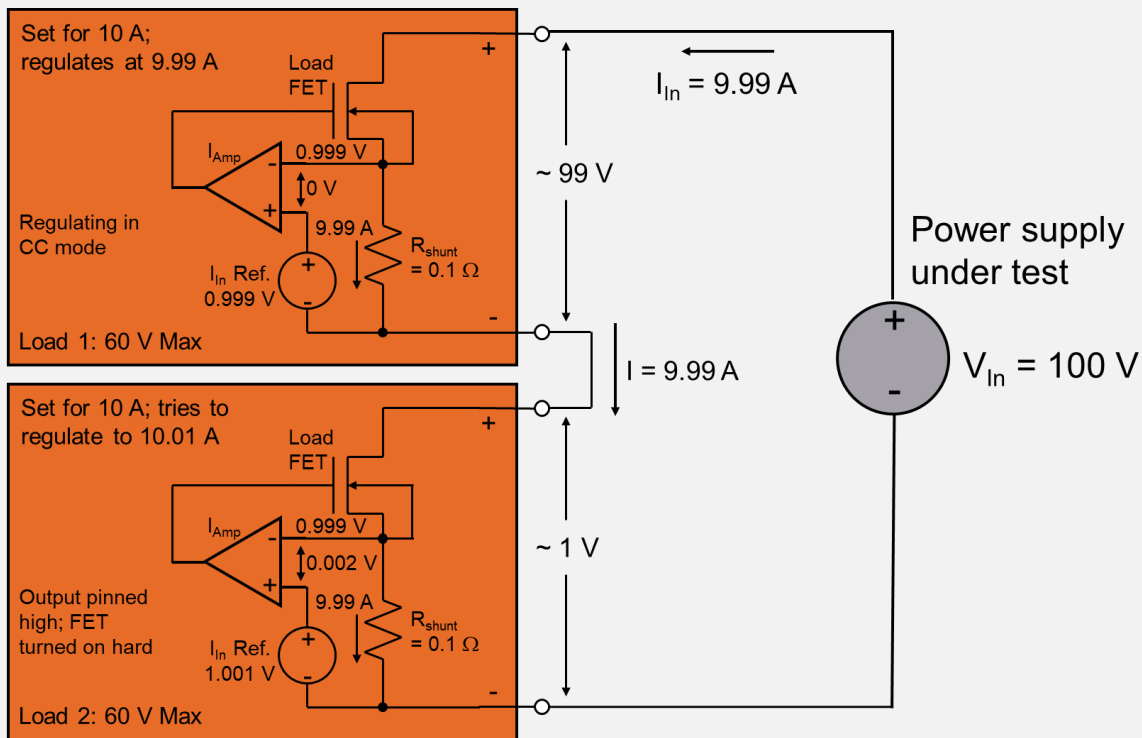

Figure 4.14 – The problem with combining loads in series.

While the same current is set on both loads and the exact same current is flowing through both loads, due to small errors in the accuracy of the settings the real set values will never be exactly equal. In the example shown Load 2 is trying to draw more current than Load 1. However, since Load 1 will limit the current at the lower value (9.99 A in this example), Load 2 can never attain its real set point (10.01 A in this example). Therefore, Load 2's internal feedback loop continues to tell its FETs to conduct more and more current until the FETs are driven so hard that they look like a short circuit. As a result, nearly all of the power supply's voltage appears across Load 1 resulting in damage to the load.

You might think that you could circumvent the above scenario and get a stable operating point by placing one load in CC mode and one load in CV mode. However, the issue with this potential solution is in getting to the stable operating point. If you set the loads first before connecting the voltage then the CC load is not satisfied (no current is flowing) so it goes to a short. In addition, the CV load is also not satisfied (no voltage is present) so it goes to an open. Thus, when you apply the test voltage all of the voltage initially appears across the open CV load (potentially damaging it). While there are other procedures you could attempt to temporarily reach a stable operating point (such as slowly increasing the test voltage if possible), any fault condition could result in one of the loads being in a short or open condition. All of this should convince you that placing loads in series can easily result in destructive voltages appearing across one or more of the loads.

## Combining loads in parallel to increase current

Fortunately, there are no issues with placing electronic loads in parallel to increase current. Since loads placed in parallel must all have ratings capable of handling the full voltage of the test source that they are sinking, there are no issues if one of the loads has any temporary fluctuations in current.

## Protection Features

Electronic loads also have similar built-in protection features to prevent damage to your DUT. However, they are different from the protection features available on power supplies as they serve different purposes.

### Over-power protection (OPP)

The over-power protection (OPP) feature places a limit on the maximum power drawn by the electronic load. If the load starts to draw more power from the DUT than the over-power protection setting, then the electronic load will turn the input off.

### Over-current protection (OCP)

The over-current protection (OCP) feature places a limit on the maximum current drawn by the electronic load. If the load starts to draw more current from the DUT than the over-current protection setting, then the electronic load will turn the input off.

### Under-voltage Inhibit (UVI)

The last electronic load protection feature, the under-voltage inhibit (UVI) setting, might seem a little non-intuitive but it makes sense when you think about it. This feature prevents the load voltage from going below a set value. If the load voltage starts to go below the UVI setting, the electronic load will turn the input off. Using this feature can prevent (for example) battery over-discharging.

## Selecting the Right Electronic Load

Use these guidelines to help select an electronic load that best fits your test requirements.

- Form factor
  - Choose a modular, small form factor solution to give you the flexibility to scale for future expansion for automated test equipment (ATE).
- Capacity rating
  - Ensure your electronic load safely manages the capacity of your power source.
  - Check that the electronic load range of operations cover your maximum voltage, current and power requirements.
- Speed
  - Choose a load to emulate fast waveforms with the appropriate slew rate.
  - Verify the load can generate and measure the signals of your application with adequate bandwidth.
  - Choose a load with a programmable slew rate and ON|OFF delays to control sequencing.

- Select a load with superior command processing time and output speed to improve and maximize your system throughput.
- Operating modes
  - CC for a power consumption test
  - CR for replacing a resistor
  - CV to test current source
  - CP to test storage capacity
- Dynamic testing
  - Identify a dynamic load with arbitrary function generation capabilities and built-in waveforms to test sine, pulse, step, ramp, or to import your profiles.
  - Ensure the load has sufficient sample rate to generate/ measure fast transient signals and sufficient memory.
  - Verify the load generates the arbitrary dynamic waveforms for necessary modes.
- Flexibility
  - Choose a modular system to mix and match different modules – electronic load and power modules – within the same unit.
  - Synchronize within a single environment to achieve a turnkey solution.
- Protection features
  - Confirm the load has built-in protection features for overvoltage, overcurrent, overpower, and overtemperature.
  - Ensure shut down features to avoid hazardous conditions on your DUT.
- Computer control
  - Load connectivity interfaces for remote programming and controlling of your instrument – GPIB, LAN, or USB.



# Chapter 5 – Batteries

## Introduction

It is safe to say that batteries and battery life are extremely important to our modern society due the ubiquitous nature of electronic devices in our daily lives. If you count up the number of battery-powered devices you use or wear on a daily basis (smart phone, watch, tablet, computer, etc.), then it becomes obvious how important it is to understand the properties of all of the batteries that these devices use. Of course, in certain applications (such as implanted medical devices) predicting battery life and reliability can literally be a matter of life and death.

## Battery Basics

### Overview

The basic power unit within a battery is the cell, and a battery consists of one or more cells connected in series or parallel. A cell has two electrodes (terminals) with some sort of chemical (known as an electrolyte) separating them. The two electrodes MUST consist of dissimilar materials, as it is the difference in the electron “affinity” that enables the battery cell to function. Essentially, when a battery is supplying power to an electronic circuit a chemical reaction occurs within the battery cell(s) that causes positive ions to flow from the negative terminal (anode) to the positive terminal (cathode). This flow of ions between the two terminals results in a positive current that the battery can supply to the circuit it is powering. As a battery generates power over time the chemicals within its electrolyte eventually become depleted of the free ions needed to continue the generation of current at its rated voltage. The battery will then stop supplying current and will also typically exhibit voltage “droop” below its specified value.

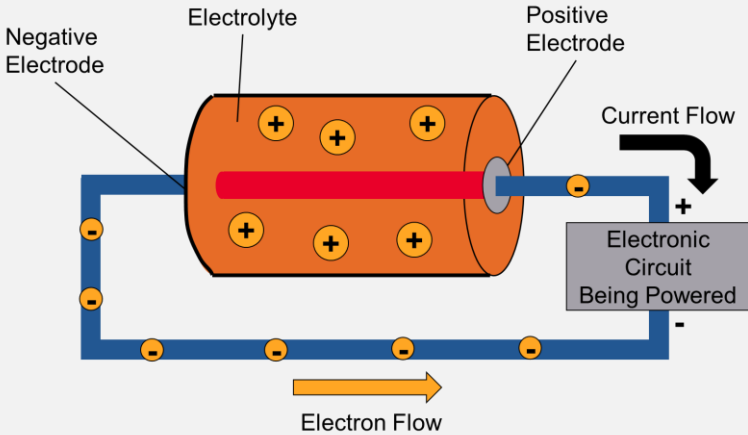

Figure 5.01 – Basic battery operation.

It is important to understand that while chemistry alone determines the voltage produced by a single battery, both chemistry and volume determine the capacity (or energy storage capability) of a battery.

For example, a 3.6 V battery cell always outputs the same voltage, but its capacity varies in proportion to the size of the cell.

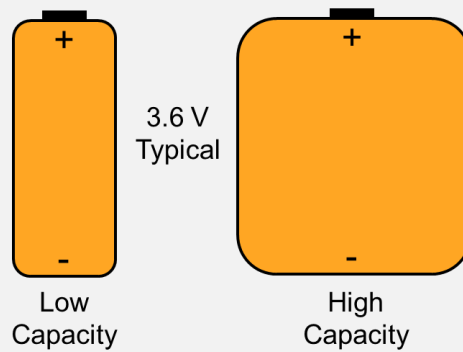

Figure 5.02 – Capacity varies with the size of the battery cell, but the voltage is always the same.

However, while you cannot change the battery cell voltage, you can combine battery cells within a battery in either parallel (to increase current, power and capacity) or in series (to increase voltage). Some advanced batteries actually contain a battery management system (BMS) that intelligently controls the fashion in which the battery’s individual battery cells work together.

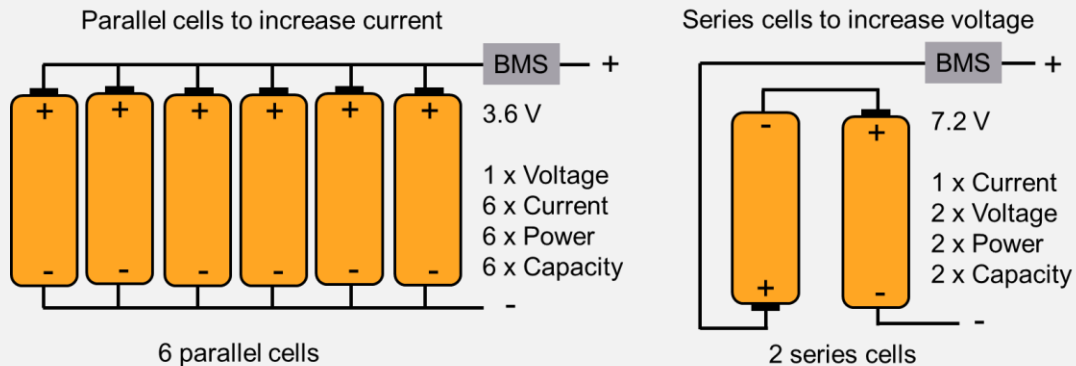

Figure 5.03 – Combining battery cells in parallel or series to achieve desired performance metrics.

Although there are a wide variety of batteries made from different combinations of electrodes and electrolytes, all batteries fall into one of two categories: primary and secondary. Primary batteries are the familiar disposable type used in a wide variety of hand-held electronic equipment. The materials used in primary batteries generally consist of three materials: zinc carbon, alkaline and lithium. Because they do not contain any liquid they are known as dry cells. You cannot recharge primary batteries, so once their internal electrolyte becomes depleted of ions you must discard them. On the other hand, you can recharge secondary batteries by passing a positive electric current into the battery’s positive terminal (the opposite situation to when they are supplying power). For this reason the common convention for secondary batteries is to refer to them as rechargeable batteries.

The first rechargeable battery was the lead-acid battery, which came into use in the nineteenth century. Although they have many advantages and are still in use widely today, lead-acid batteries are also large, heavy, expensive and have limited charge/discharge cycles. For a number of years nickel-cadmium (NiCd) and nickel-metal-hydrate (NiMH) rechargeable batteries served as substitutes for 1.5 V disposable batteries in items such as toys, flashlights and power tools. However, the toxic metals used in these batteries and their need to be near fully discharged before recharging prompted the search for a better alternative. Lithium-ion batteries have now become the dominant and fastest-growing class of rechargeable batteries, and they appear in a range of modern electronics from cell phones to electric cars.

	Nickel-Cadmium	Gelled Lead Acid	Lithium	Carbon Zinc	Alkaline	Silver Oxide	Mercuric Oxide
Volts/Cell	1.2	2.0	1.5 to 1	1.5	1.5	1.5	1.4
Charge Method	CC	CV, float charge	N/A	N/A	N/A	N/A	N/A
Cycle Life	500+ cycles	200 cycles	N/A	N/A	N/A	N/A	N/A
Life (Charged)	3 mos. (-2%/day)	1 year	5 to 10+ years	1 to 5 years	5% loss/yr.	6% loss/yr.	4% loss/yr.
Operating Temp.	20° C to 70° C	-20° C to 65° C	-55° C to 75° C	-5° C to 55° C	-30° C to 55° C	-20° C to 55° C	-10° C to 55° C

## Battery Electrical Ratings

A battery's capacity rating is based on the total amount of charge the battery can deliver. Of course, this directly impacts the amount of current it can supply over time, which has the units of Ampere-hours (A-h). A battery's capacity rating has the units of coulombs (C), where:

- 1 coulomb (C) = 1 Ampere-sec
- 1 Ampere-hour (Ah) = 3,600 coulombs

A battery's energy rating is the total amount of energy the battery can deliver, which is determined by the power that it can deliver over time. The energy rating has the units of Watt-hours (W-h), and it is equivalent to the product of the battery's capacity (A-h) and voltage (V). You can also express battery energy ratings in Joules (J) where:

- 1 joule (J) = 1 watt-second
- 1 Watt-hour (W-h) = 3,600 joules

Another fundamental parameter is a battery's charge (or discharge) rate, which is known as its C-rate. This is the ratio of the level of current supplied to (or drawn from, when discharging) to the battery's capacity where:

- C-rate (C) = current (A) / (capacity (A-h))
- C-rate (C) = 1 / charge or discharge time

Note that although the C-rate has the abbreviation of “C”, its units are NOT charge and it does not represent Coulombs.

The type of battery and its design has a large impact on the battery's C-rate. For example, batteries for power tools have a high C-rate capability (10 C or greater) as they need to deliver high levels of power over short time periods. In contrast, batteries used in portable wireless mobile devices need to run for long time periods so they utilize batteries with low C-rates. When evaluating a battery's capacity testers typically use a C-rate considerably lower than its maximum value since higher C-rates yield lower battery capacity results due to internal battery losses. Validating a battery's capacity and energy ratings requires logging the battery's voltage and current over an extended period of time, most often using a regulated constant current load.

### Battery Profiling and Emulation

Battery profiling is the process of measuring battery behavior to create an electrical representation of battery characteristics (i.e. create an electrical battery model). Battery emulation is the process of using a power supply to mimic battery behavior (using a derived battery model) to power a DUT. Obviously, these are different but related tasks. The most common battery model consists of a voltage source and series resistance as shown in the following figure.

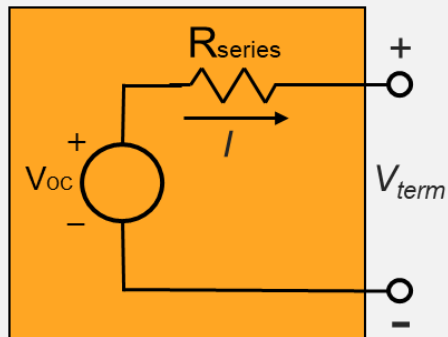

Figure 5.04 – The most common battery model.

A constant current load applied to a battery allows you to derive the battery's open circuit voltage and series resistance. The following list describes this process.

1. Slowly discharge a fully charged battery using a constant current load.
2. Use the current drawn from the battery over time to compute the charge removed from the battery and estimate the battery's charge level or state-of-charge (SoC).
3. Measure and record the battery's voltage and series resistance at user-specified time points and record the values.

The following figure shows some example data taken on a battery using this process.

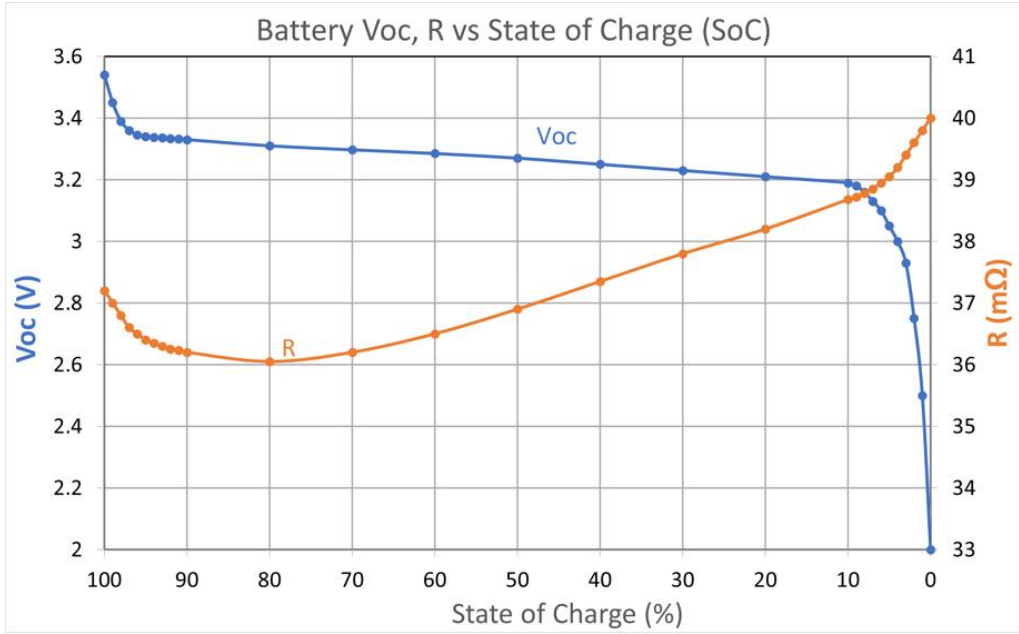

Figure 5.05 – Example showing battery open circuit voltage and series resistance plotted versus battery state-of-charge

This data shows that both the battery open circuit voltage and series resistance are functions of the battery state-of-charge (SoC), so if you need more accuracy for battery emulation then you must take these effects into account. This requires measuring the open circuit voltage and series resistance at regular intervals as you discharge (or charge) the battery and recording the results in a lookup table.

It is also important to understand that battery characteristics depend strongly upon temperature. The following graph shows battery voltage versus the percent of used battery capacity.

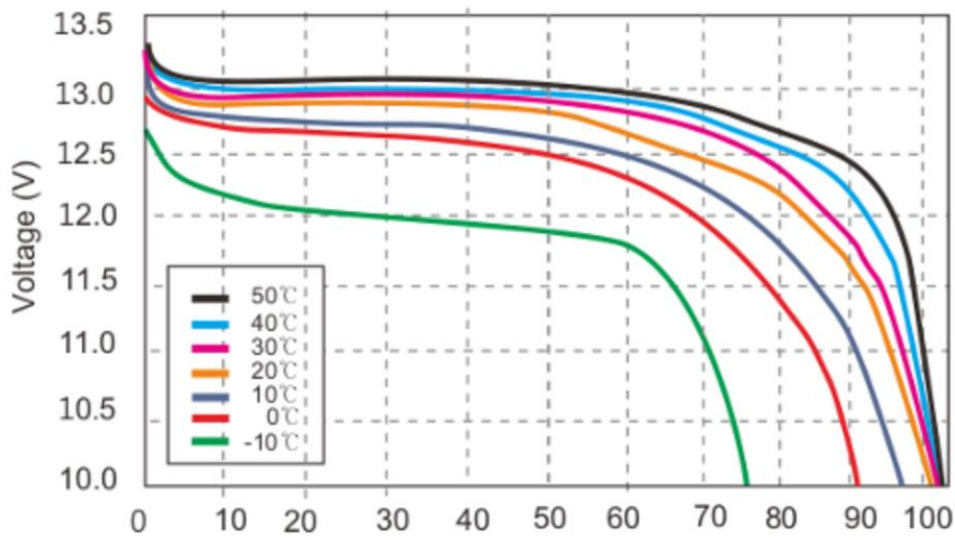

Figure 5.06 – Graph showing the effect of temperature on battery voltage versus percent of used battery capacity (rated).

Therefore, a more complete battery model also needs to take the effect of temperature on battery characteristics into account.

When emulating a battery using a power supply, we can rank the models (from basic to more advanced) as follows:

1. Constant voltage source – The power supply is simply set to a constant output voltage.
2. Include output resistance – The output path includes a series resistance.
3. Static SoC – Modify the output voltage and series resistance to conform to values at a specific state-of-charge (SoC).
4. Dynamic SoC – Dynamically change the output voltage and series resistance using state-of-charge (SoC) values based on the current flow out of or into the emulator.
5. Temperature dependence – Include the effects of temperature on the output voltage and series resistance.
6. Additional circuit elements – Incorporate additional circuit elements (such as RC networks) to better emulate transient current behavior.

We will briefly look at each of these models in-turn.

The most basic emulator is simply a power supply set for the battery voltage. The power supply terminal voltage ( $V_{term}$ ) is constant and never changes. The following figure shows a schematic of this model.

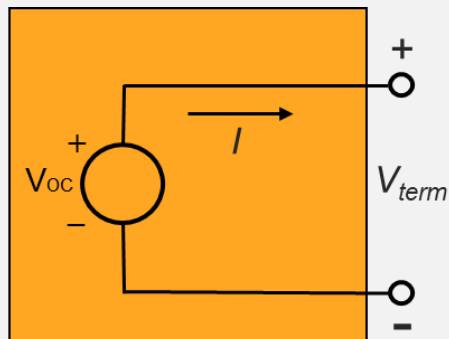

Figure 5.07 – The most basic battery model consisting of a constant voltage source.

$$V_{term} = V_{oc}$$

From our previous discussions of battery chemistry and physics it should be clear that this model is too simplistic except for the most basic of battery emulation applications.

The most commonly used battery model is the previously mentioned voltage source and series resistor equivalent circuit. The following figure shows a schematic of this model.

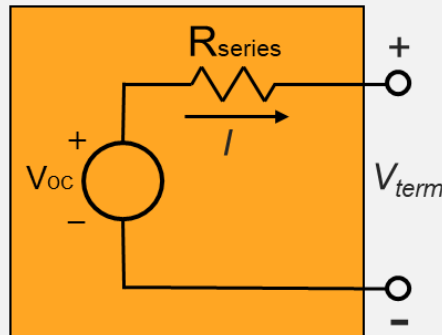

Figure 5.08 – A better battery model that includes battery series resistance.

$$V_{term} = V_{oc} - I \times R_{series}$$

The voltage ( $V_{term}$ ) changes proportionately to the current drawn from the power supply and this model works quite well for a variety of applications. However, in reality we know that the values of  $V_{oc}$  and  $R_{series}$  are not constant but vary according to the battery's state-of-charge.

The next step in improving the battery model is to use different values for  $V_{oc}$  and  $R_{series}$  based on a particular point in the battery's state-of-charge. Most batteries supply a graph of the open circuit voltage versus the state-of-charge. Therefore, if the  $V_{oc}$  and  $R_{series}$  graph data are available and you know the SoC you want to evaluate, then you can set the power supply  $V_{oc}$  and  $R_{series}$  to appropriate values based on lookup tables derived from the graphs. Once set, the power supply voltage ( $V_{term}$ ) does not change except for the voltage drop caused by the series resistance. The following figure shows a schematic of this model.

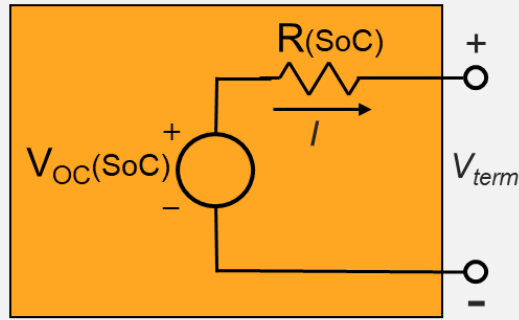

Figure 5.09 – A battery model that takes variations in  $V_{oc}$  and  $R_{series}$  into account at a fixed point of state-of-charge.

$$V_{term} = V_{oc} \text{ as } f(\text{SoC}) - I \times [R_{series} \text{ as } f(\text{SoC})]$$

Although this model uses a fixed value for the state-of-charge, you can re-run it with different values for  $V_{oc}$  and  $R_{series}$  to represent different states-of-charge for the battery.

The previous model used a single static value for the state-of-charge, so the obvious next step is to dynamically model the battery's state-of-charge and adjust the  $V_{oc}$  and  $R_{series}$  values appropriately. If you know the initial value for the battery's state-of-charge and you have graphs (or lookup tables) plotting  $V_{oc}$  versus SoC and  $R_{series}$  versus SoC, then you can calculate state-of-charge dynamically and use adjusted values for  $V_{oc}$  and  $R_{series}$  at a particular point of battery discharge. The following figure shows a schematic of this model.

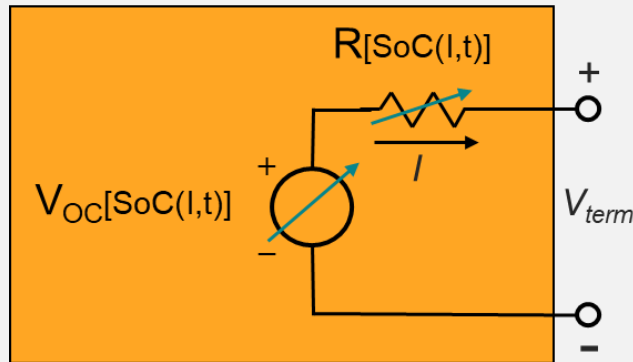

Figure 5.10 – A battery model that takes dynamic variations in  $V_{oc}$  and  $R_{series}$  into account as a function of state-of-charge.

$$V_{term} = V_{oc} \text{ as } f[\text{SoC}(I, t)] - I \times \{R_{series} \text{ as } f[\text{SoC}(I, t)]\}$$



Note that this model shows the values of  $V_{oc}$  and  $R_{series}$  as functions of current ( $I$ ) and time ( $t$ ) since they determine the state-of-charge.

If we want to improve our battery model further, then the next factor to consider is temperature. The battery temperature can change due to both environmental conditions and self-heating effects when charging or discharging. Therefore, in addition to using lookup tables to determine  $V_{oc}$  and  $R_{series}$  as a function of the state-of-charge, using the initial temperature and the thermal properties of the battery we can use additional lookup tables to include temperature effects. The following figure shows a schematic of this model.

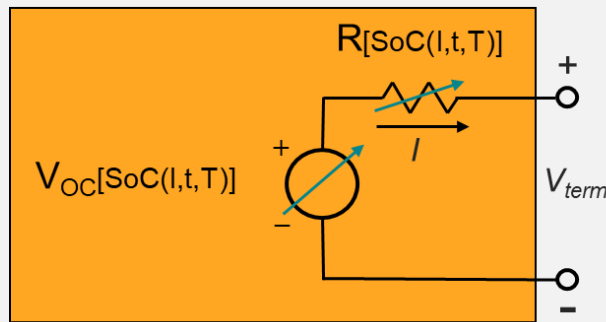

Figure 5.11 – A battery model that takes dynamic variations in  $V_{oc}$  and  $R_{series}$  into account as a function of both state-of-charge and temperature.

$$V_{term} = V_{oc} \text{ as } f[SoC(I, t, T)] - I \times \{R_{series} \text{ as } f[SoC(I, t, T)]\}$$

Finally, in addition to accounting for the effects of state-of-charge and temperature on  $V_{oc}$  and  $R_{series}$ , we can make further refinements to the model by including RC networks to better represent the battery's transient response.

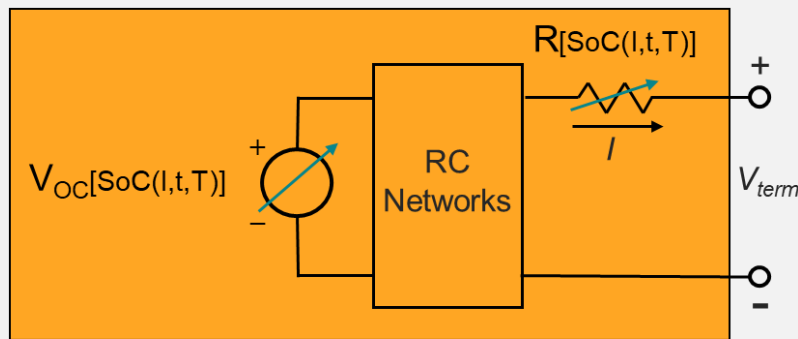

Figure 5.12 – More complex battery models add additional RC networks to the dynamic  $V_{oc}$  and  $R_{series}$  model to better represent the battery's transient response.

Of course, the equation used to define  $V_{oc}$  and  $R_{series}$  are the same as for the previous case.

## Measuring Battery Resistance versus State-of-Charge

We have covered the most common battery model consisting of a voltage supply and series resistance, but we have not discussed how to determine their values. Since both of these parameters depend upon the state-of-charge, we must measure them at different values of state-of-charge as we drain the battery. This requires us to make a resistance (or impedance) measurement, and there are two approaches to this:

1. DC Internal Resistance (DCIR)
2. AC Internal Resistance (ACIR)

We will discuss both in-turn.

The DCIR method requires a two-quadrant current source with measurement capability. The current source also has to have the ability to apply current pulses at pre-specified points along the state-of-charge curve, which requires continuous current monitoring to keep track of the battery's charge level. The following figure shows a functional diagram of this technique.

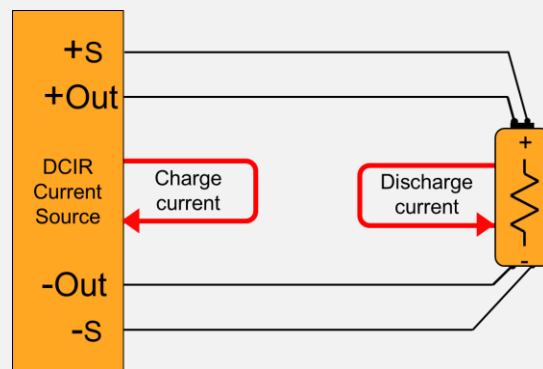

Figure 5.13 – Measurement setup to determine series resistance versus state-of-charge for the DCIR method.

The key points of the DCIR current source measurement technique are:

- It provides a current pulse on the Force terminals (+Out and -Out)
- It measures the cell's voltage response on the Sense terminals (+S and -S)

We will look at an example using 100 A charging and 100 A discharging pulses to illustrate how this technique works. An important point is that we need to keep the pulses short to minimize the effect on battery SoC, as they impact both the open circuit voltage and series resistance. In addition, we must do both a charge and discharge cycle so that we end up at the same SoC after completing the resistance measurement. The following figure illustrates the current and voltage waveforms used in this technique.

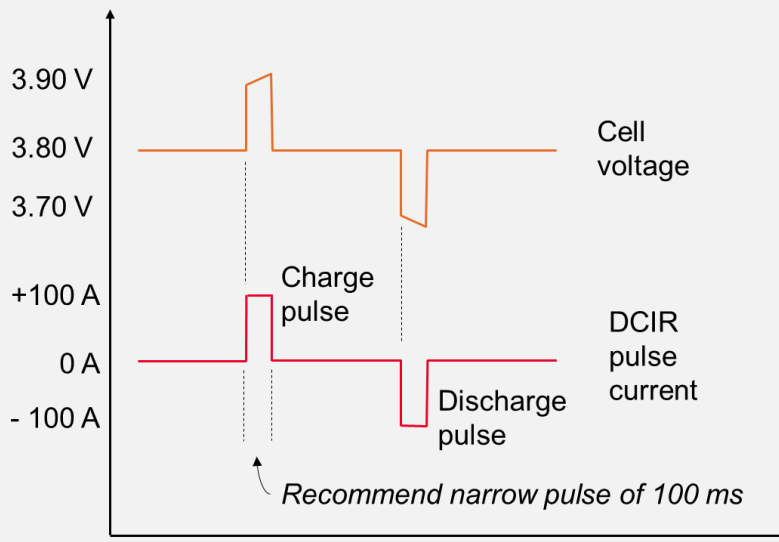

Figure 5.14 – Example showing DCIR measurement using 100 A charge and discharge pulses.

The following figure shows how to make the DCIR measurement using a charge pulse.

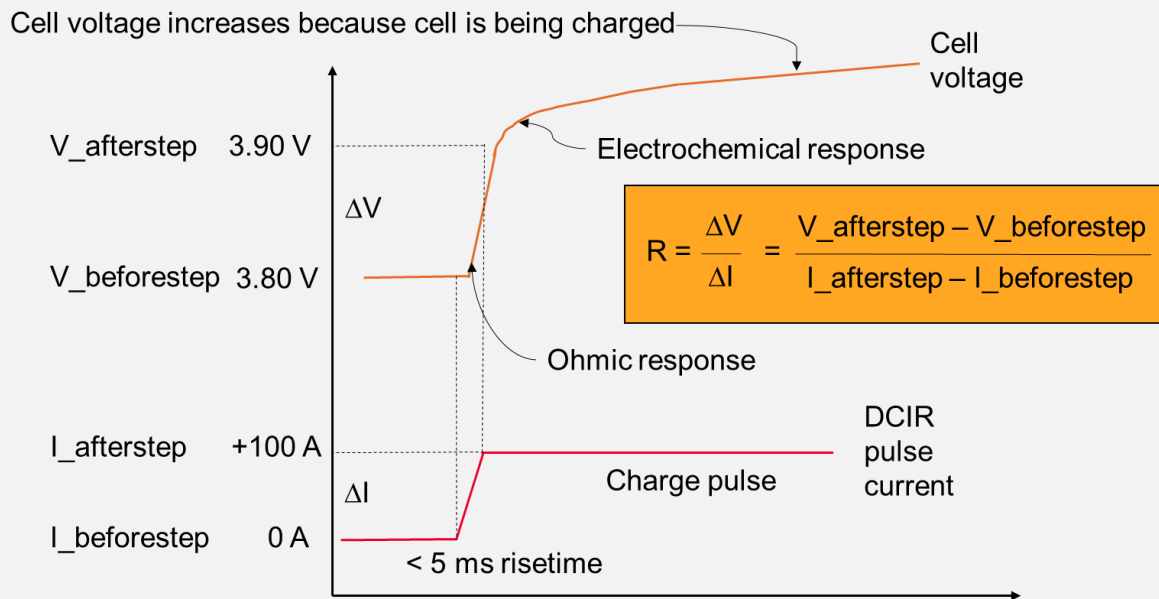

Figure 5.15 – Measuring DCIR from a charge pulse.

The following figure shows how to make the DCIR measurement using a discharge pulse.

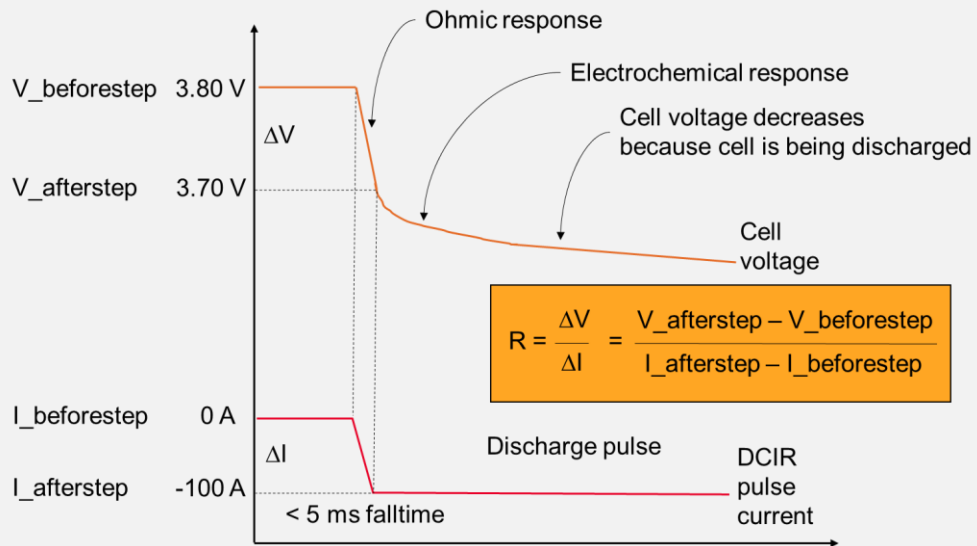

Figure 5.16 – Measuring DCIR from a discharge pulse.

The ACIR method is considerably more complicated in terms of equipment required and the test procedure. The following list shows the required test equipment.

- Function generator to create a 1 kHz waveform
- Coupling transformer
- AC ammeter to measure RMS current
- AC voltmeter to measure RMS voltage
- An oscilloscope to measure magnitude and phase.

The following figure shows the basic circuit used to perform an ACIR measurement.

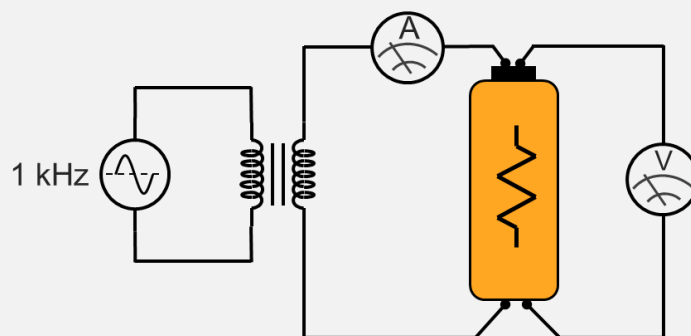

Figure 5.17 – Configuration to measure battery impedance.

The basic equation used to derive the impedance is straightforward:

$$\text{Battery Impedance} = \frac{\text{AC Voltage Across Battery}}{\text{AC Current Flowing thru Battery}}$$

However, since impedance is a complex quantity we have to measure the AC voltage and current magnitude and phase in order to arrive at the battery impedance.

## Standard Battery Test Procedures

There are seven standard test procedures used to verify the electrical characteristics of secondary batteries (as specified in ANSI® C18.2-1984, American National Standards). They are:

1. Rated capacity
2. Capacity retention
3. Effective internal resistance
4. Discharge rate effect on capacity at –20°C
5. Discharge rate effect on capacity at 23°C
6. Life cycle performance
7. Extended overcharge

Other miscellaneous tests and procedures also involve discharging a battery such as: start-up voltage test, forced-discharge test, timed fast charge and dump-timed charge. Most battery tests typically require only about 1% accuracy unless otherwise specified. While battery tests do not require high accuracy, the tests must be very repeatable. Since battery characteristics change with temperature it is important to be able to control and monitor the temperature, usually to within ±2 degrees C. Other equipment requirements to consider are a current source for charging secondary batteries, a voltage monitor, a current monitor, a load for discharge current, and a time keeping device.

## Rated Capacity

The principal measurement of a battery's performance is its rated capacity. To obtain capacity ratings you need an accelerated test approximating the battery's capacity in typical use. We define the capacity of a fully charged battery, at a fixed temperature, as the product of the rated discharge current (in amperes) and the discharge time (in hours) to a specified minimum termination voltage (volts). We consider a battery completely discharged when it attains the specified minimum voltage called the "end of discharge voltage" (EODV). The EODV for nickel-cadmium batteries is typically 1.1 to 0.9 Volts.

We previously discussed the concept of battery C-rating in the battery basics section in which we noted that it has units of ampere-hours. We define the term 1 C as the rate of discharge that allows a battery to provide its rated current over a period of one hour. Capacity varies with the rate of discharge as shown in the following figure.

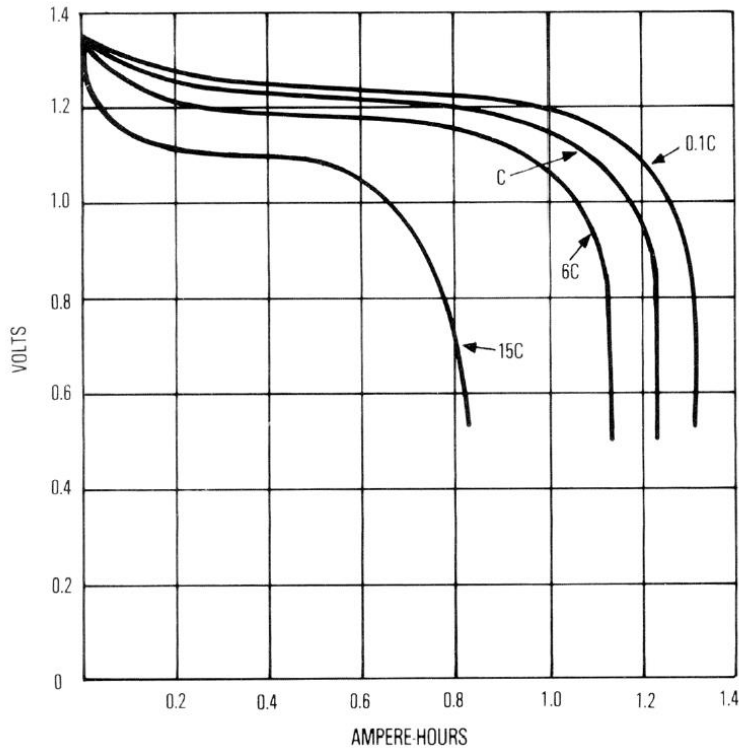

Figure 5.18 – The effect of discharge rate on battery capacity.

We will discuss testing how discharge rate affects capacity later in more detail. Generally, lower discharge rates over longer periods of time yield higher values of total capacity. It is important to realize that since discharge rate affects the measured value of C, battery manufacturers must decide on a standard time of discharge. Since you can obtain different values for capacity for the same battery, when specifying capacity manufacturers generally specify a “standard” period of time (from 5 to 20 hours) at discharge rates from C/5 to C/20. A complete specification for capacity should therefore have a C rate and the period of time used for the test to determine the capacity. For example, Capacity: 450 mA-h @ 5 hour rate.

To obtain average and maximum battery capacities, testers put the battery through five successive charge/discharge stabilizing cycles. They give the batteries five stabilizing cycles where they charge, discharge and rest the batteries at an ambient temperature of 23 degrees C. They charge the batteries at C/10 A for a period of from 20 to 24 hours and rest them for a period of from 2 to 4 hours. They then discharge the batteries at a constant current of 1C amperes to an EODV of 0.9 volts.

The value of the capacity used in the following tests is the value obtained in the fifth stabilizing cycle. Also, the capacity obtained in the last three cycles must not be less than that stated by the manufacturer as rated capacity (1 C).

## Capacity Retention

This test characterizes how much of a fully charged battery's capacity it retains over a long period of time under specific conditions. Common usage refers to this time as the "shelf life" of the battery. This test is not to be confused with an attempt to characterize the self-discharge effect of the spontaneous internal chemical actions in batteries. Self-discharge occurs regardless of the battery's connection to an external circuit.

The procedure to determine the effective capacity retention of a battery is relatively simple. Immediately following the 5 cycles of capacity measurement, the battery is fully recharged. You then store it open circuit for a period of days at a specific temperature. You then discharge it at a constant current rate to an EODV of 0.9 V as before. The capacity obtained should not be less than 37% of the rated capacity for the battery. Typical battery specs provide the number of days of shelf life for values of temperature from 23° C to 50° C.

## Effective Internal Impedance

Battery impedance is dependent on temperature, its state of charge, and the load frequency. The effective internal impedance is lower for a fully charged battery than it is for a discharged one. Having a low internal resistance is very important when the battery must support a high current for a short time. Low temperature, use, and long storage periods all increase a battery's internal resistance. Nickel-cadmium batteries also have a high effective capacitance. Their total effective impedance is so low that, in applications where they are continuously being "trickle-charged" at rates from 0.01C to 0.1C, they make excellent ripple filters. The following paragraphs explain resistance and impedance tests.

## Resistance Test

The battery must be in a state of full charge as outlined above. For batteries rated 5 A-h or less the procedure is to discharge them at a rate of 10 C for 2 minutes and then switch to a rate of 1 C. You record the battery voltage just prior to switching and again upon reaching its maximum value after switching. You need to make all voltage measurements at the terminals of the battery independently of the contacts used to carry current.

You can determine the effective internal resistance ( $R_e$ ) using the following equation:

$$R_e = \frac{\Delta V}{\Delta I} = \frac{V_H - V_L}{I_H - I_L}$$

where

$I_H, V_H$  = The current and voltage, recorded just prior to switching

$I_L, V_L$  = The current and maximum voltage, recorded after switching

## Impedance Test

The battery must be in a state of full charge as outlined above. You then apply an AC current source (~1 kHz) to the terminals of the battery and measure the AC current through the battery and the voltage across it. You can then easily calculate the impedance as  $V/I$ . An interesting alternative testing method that yields the same result is to place a varying (~1 kHz) load across the fully charged battery instead of the AC power source.

## Discharge Rate Effect on Capacity

The rate of discharge has an effect on the total capacity of a battery. Heavy discharge rates decrease the total available capacity of a battery. You need to perform this test at two temperatures:  $-20^{\circ}\text{C}$  and  $23^{\circ}\text{C}$ . You first fully charge the battery at  $23^{\circ}\text{C}$  and then immediately store it for 24 hours at an ambient temperature of  $-20^{\circ}\text{C}$ . You then discharge the battery at an ambient temperature of  $-20^{\circ}\text{C}$  at a constant current rate of 1 C to an EODV of 0.8 V. You then repeat this procedure at discharge rates of 5C and C/5. You then repeat the whole test at a temperature of  $23^{\circ}\text{C}$  to an EODV of 0.9 V.

For each of the six discharge cycles, the manufacturer supplies the value of capacity they expect as a percent of C1. You should avoid charging and discharging at temperatures below the specification sheet recommendations.

## Life Cycle Performance

Life cycle testing is a measure of expected battery performance in actual service. We characterize life cycle performance by dynamically loading the battery in a simulated “real-life” situation for 50 or more charge and discharge cycles as follows:

You first apply five stabilizing cycles to the battery in accordance with the previously outlined procedure.

Life Cycles 1 through 48

1. Charge 11 hours and 20 minutes at C/10
2. Discharge immediately at 1 C for 40 minutes
3. No rest

Life cycles 49 and 50

1. Charge for 20 hours at C/10
2. Rest 2 to 4 hours
3. Discharge at 1 C to 0.9 volts
4. EODV

### **Repetition of Life Cycles**

Repeat cycles 1 to 50 as desired. The capacity at cycle 50, and multiples thereof, should be no lower than that stated for this procedure by the manufacturer.

## Extended Overcharge

The ability of a battery to withstand overcharge is determined by charging the battery at a constant current of C/10, or at the maximum overcharge rate recommended by the manufacturer, at an ambient temperature of  $23^{\circ}\text{C}$  for 6 months. The battery should at no time show either electrolyte leakage or visual evidence of distortion beyond the standard maximum dimensions for that battery. When discharged at a constant current of 1 C to an EODV of 0.9V, the battery should have a capacity equal to or greater than the extended overcharge capacity specification.



## Miscellaneous Tests

In addition to the tests already mentioned, there are also other miscellaneous tests performed on nickel-cadmium batteries. These tests usually involve high rate charge and/or discharge. High rate discharge and charge of nickel-cadmium batteries is possible with today's new and better designed cells having advanced plate and cell construction. The low internal resistance of nickel-cadmium batteries yields high discharge currents. If you discharge them continuously under short circuit conditions, then self-heating may do irreparable damage. You need to avoid continuous discharge at rates greater than 1C to avoid potentially hazardous conditions due to high internal gas pressure build-up.

You can withdraw very high currents (>2 C) in low duty cycle pulses providing that you maintain internal temperatures and pressures. Output capacity in any type of pulse discharge application is difficult to predict because of the infinite number of possible combinations of discharge time, rest time, and EODV. Simulation of actual events, as in the Life-Cycle test, is the best way to quantify a battery exposed to such conditions.

Many cells can be quick charged at a rate up to C/3 in as little as 3 to 5 hours instead of the standard 12 to 15 hours at the C/10 rate. In this case you should perform high rate charging under controlled conditions where you can monitor temperature, voltage, pressure, or some combination of these parameters to assure they are within specifications.

One fast-charge method involves charging the battery at a rate exceeding the specified maximum charge rate for a finite period of time, after which you reduce the charge rate to currents below C 10. This method, called "timed fast charge," can indeed give a quick "boost" charge to a partially discharged battery, but unfortunately has the potential of permanently destroying the battery. The destruction occurs due to overcharging the battery because its unused capacity is unknown prior to charging.

There is a safer variation of the timed fast charge method known as "dump timed-charge" where you first fully discharge the battery ("dumped") to its EODV before recharging via the "timed fast charge" method. The "dump timed-charge" method has the advantage of providing you with information as to just how much energy you must pump back into the battery to bring it to full capacity. It also eliminates the risk of overcharging.

One final test, called the "forced discharge test," determines the safety of a battery under certain abusive conditions. This test is very dangerous because, during the test, the battery is very likely to explode. Therefore, you must perform this test under extremely well controlled conditions in an explosion proof safety chamber to prevent personal injury. The test involves connecting a current source in series with the battery. The polarity is in the same direction as normal or short circuit current flow as shown in the following figure.

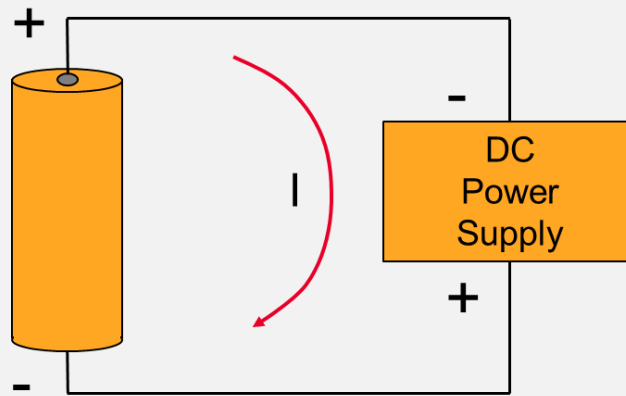

Figure 5.19 – Battery forced discharge test.

The current source is set to a value such that the resultant current flow is greater than the short circuit current flow. This test simulates what may happen if someone improperly installs a battery in a circuit where it may not be the only source in the application. Ideally the battery should withstand the stress, with some degree of margin, when the test currents are similar to actual conditions.

## Battery Test Equipment Requirements

From the various tests described so far, we can see some common requirements for test equipment. All the tests require a discharge cycle using a constant current. You cannot attain a constant discharge current with a simple resistor because the battery voltage changes as you draw current from it. You need an active device, such as an electronic load with a constant current mode of operation. Also note that, because you need many levels of constant current from test to test, you should be able to control the electronic load dynamically as the test demands.

The ability to control the load with a computer is important because discharge is typically over a long period of time and, if the test were not automated, constant attendance would be an unproductive use of an operator's time. Long term tests also bring about another requirement: reliability. The electronic load must be very reliable because, if it should fail, the test would take a long time to repeat.

In battery or single cell testing the electronic load only has to function down to the EODV, not zero volts as shown in the following figure.

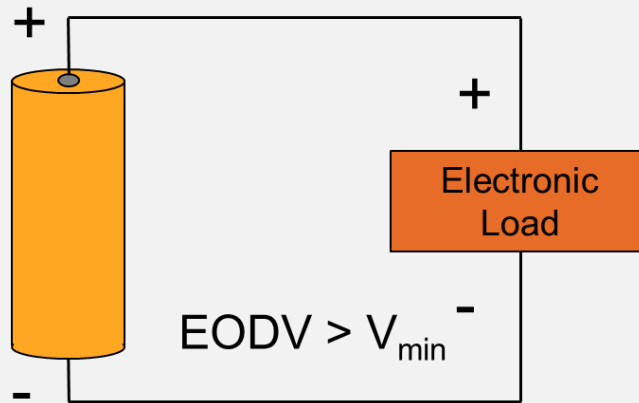

Figure 5.20 – In battery test an electronic load only has to function down to the end of discharge voltage (EODV).

If the minimum load operating voltage is above the EODV for the battery under test, two alternatives are available. The first is to stack more than one battery in series until you reach the required voltage as the following figure shows.

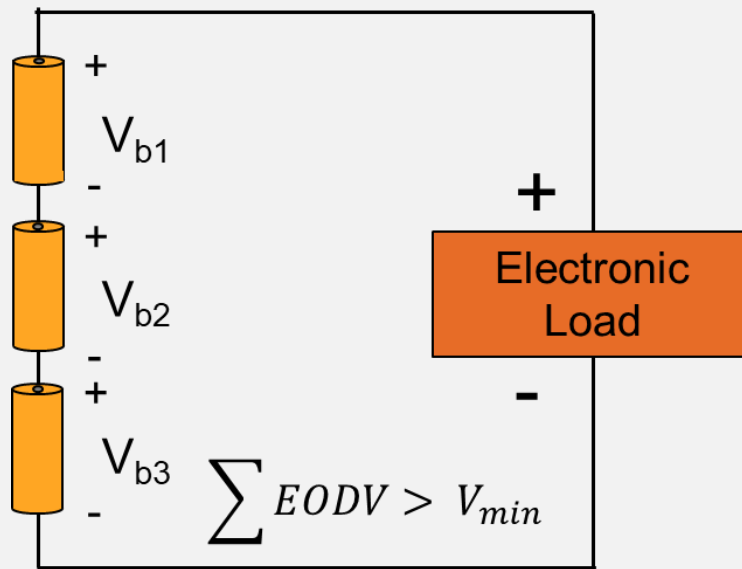

Figure 5.21 – Stacking batteries in series to overcome electronic load limitations.

The second option is to place a DC power supply (of sufficient voltage and current) in series with the battery as shown in the following figure.

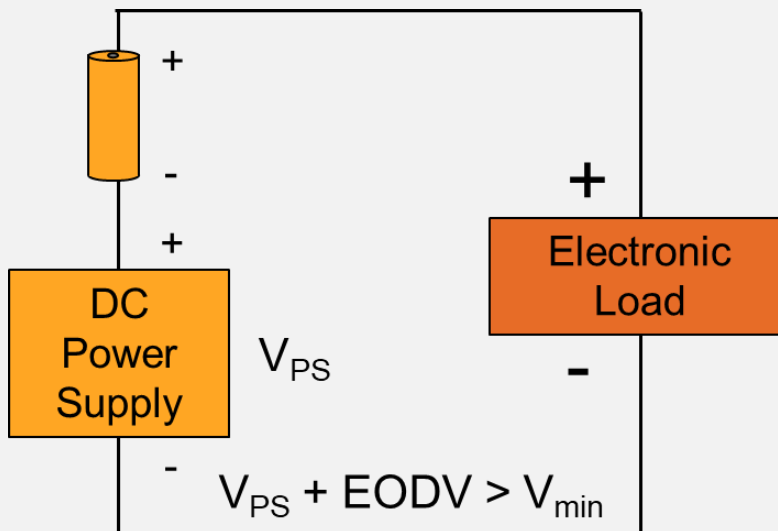

Figure 5.22 – Using a DC power supply in series with a battery to overcome electronic load limitations.

The typical term for a power supply applied in this way is an “offset supply.”

The first alternative (Figure 5.21) requires a method of scanning the voltage of each battery in the stack so that when any one battery reaches its EODV, either the equipment is able to halt the test or it switches the battery out of the circuit and replaces the battery by a short circuit. Even as you switch each battery out of the circuit, the discharge current will remain the same if the load has a constant current mode of operation.

The second alternative (Figure 5.22) shows that using a power supply may be more desirable because timed fast charge, dump-timed charge, and forced discharge tests all require a DC power source anyway. Additionally, you can then use a constant current power supply to test ampere-hour efficiency of secondary batteries. This rating is simply the ratio of the ampere-hours delivered during discharge to the ampere-hours required to restore the initial state of charge to the battery.

You must monitor voltage and current throughout all the tests because actual battery voltage varies with the battery chemistry as well as the discharge rate involved. Therefore, you need both a voltmeter and an ammeter. They should be computer controlled so that it can halt the various tests when the battery reaches EODV. If an ammeter is unavailable, you can use a current shunt in conjunction with either a second voltmeter or a scanner.

Of course, a two-quadrant power supply capable of both sourcing and sinking current could perform the tests just covered. Keysight's advanced power supplies (N6900 and N7900 series) and regenerative power supplies (RP7900 series) provide this flexibility along with excellent current and voltage measurement capabilities.

## Battery Testing with Electronic Loads

Keysight Technologies' Electronic Loads are ideally suited for battery test applications. Their many features make the test system easy to configure and provide safe, reliable, and repeatable operation. The Keysight N3300A Series Electronic Load Mainframe and the N6790 Series of Electronic Load Modules have the required constant-current modes as well as constant resistance and constant-voltage modes. Built-in voltmeters and ammeters eliminate the need for external meters and provide measurement accuracy which, in most cases, greatly exceeds the 0.5 to 1% accuracy requirement.

You can control these electronic loads from their front panel, from a computer via GPIB, or by a 0 to 10 volt analog signal. By varying the analog control input (up to 10 kHz), you can easily measure a battery's effective internal impedance. The electronic load's built-in GPIB interface makes it simple to connect any computer that supports GPIB. In addition to controlling Keysight's electronic loads over the bus, you can also read back measured current, voltage, power and complete status, allowing you to automate time consuming discharge tests. Keysight's electronic loads truly provide a "One Box" solution.

You can easily test cells down to an EODV of 0.9 volts with Keysight N3300A electronic loads. While the operating characteristics of these loads meet all specifications above 3 volts, the DC operating characteristics extend below 3 volts as the following figure shows.

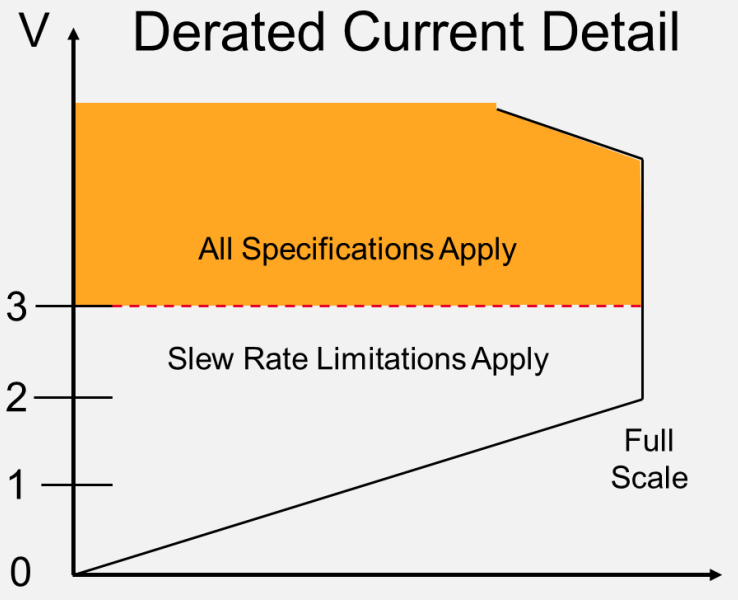

Figure 5.23 – The operating characteristics of a Keysight N3300A series electronic load.

This following table shows that at 0.9 volts the Keysight N3300A Electronic Load is capable of reliably drawing up to 30 amperes.

Voltage	N3302A	N3303A	N3304A	N3305A	N3306A	N3307A
2.0 V	30 A	10 A	60 A	60 A	120 A	30 A
1.5 V	22.5 A	7.5 A	45 A	45 A	90 A	22.5 A
1.0 V	15 A	5 A	30 A	30 A	60 A	15 A
0.5 V	7.5 A	2.5 A	15 A	15 A	30 A	7.5 A
0 V	0 A	0 A	0 A	0 A	0 A	0 A

That means you can discharge an 80 Ah battery to an EODV of 0.9 volts at a discharge rate of C/3. In addition, for applications requiring V/I characteristics below the operating curve of Figure 5.23, you can use Keysight DC power supplies as offset supplies.

## Chapter 6 – Power Conversion

### Introduction

Chapter 4 covered AC to DC power conversion, as this is what most people think about when they see the words “power supply.” However, this is not the only type of power conversion that we need to understand. Other types of power conversion are also very important for many modern power applications, and we will examine all of them in-turn.

### DC to DC Conversion

DC to DC converters take a DC input voltage and convert it to another DC. Almost all modern battery-powered devices of any complexity employ one or more DC to DC converter circuits to reduce the voltage of the supply battery down to a level appropriate for its internal circuitry. However, applications such as high-voltage DC power transmission also use DC to DC converters. The key point of a DC to DC converter circuit is that its output needs to act just like a battery in the sense that it needs to maintain a stable output voltage regardless of current loading.

The purpose of this handbook is not to teach circuit design. However, it is worthwhile to understand some fundamentals as to how DC to DC converters work before moving on to the subject of testing them. DC to DC converter design techniques and choices are actually similar to the linear and switching techniques employed by AC to DC power supplies. DC to DC converters employing linear voltage regulation techniques have the advantage of simplicity, innately low drift and minimal RF emissions. However, just like switching power supplies they have the disadvantage of inefficiency, in that they dissipate excess energy as heat. For this reason, most modern DC to DC converters use some sort of switching technique. Switch mode DC to DC converters work by converting their input voltage into an alternative energy form and then converting this energy back out at another voltage level. The energy storage is either done magnetically (using transformers or inductors) or electrically (using capacitors). Switch mode DC to DC converters are complex circuits that require careful design to insure stable output and minimal RF noise. However, today they are widely available as integrated circuits and they offer excellent performance. In the next section we will explore ways to verify their performance.

### DC to DC converter testing overview

The following are some of the most common DC to DC converter performance metrics and tests:

1. Efficiency – The ratio of output power to input power.
2. Load Regulation – Output stability under varying output loads. In other words, as the current draw of the powered device(s) changes does the DC to DC converter’s output remain stable?
3. Line Regulation – Output stability under varying input voltage. This parameter relates to how stable the output voltage is as the input voltage is varied (under constant load conditions).
4. The time-based response of the output to sudden changes in output load. Essentially, this test looks to see if the output shows any glitches if you change the output load abruptly.

What are the requirements for DC to DC converter testing? Regardless of the size of the converter, you need a DC source to provide input power to the converter under constant voltage and you need an

electronic load to draw power from the output (usually under constant current loading). You need to sweep the load current from zero to the full load current capability of the DC to DC converter while recording input power (input voltage times input current) and output power (output voltage times output current). The efficiency is then the ratio of power out to power in, most often expressed in a percentage. The following figure illustrates this test setup.

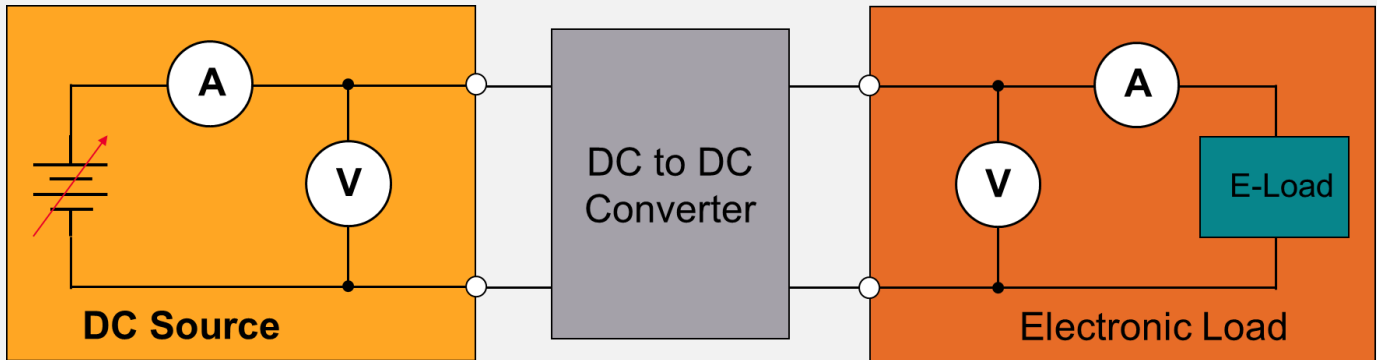

Figure 6.01 – The basic setup to test a DC to DC converter.

In addition to sourcing and sinking power, you need precision current and voltage measurement on both the input and output synchronized to the load current as it sweeps.

If you are testing small DC to DC voltage converters then often one major challenge is finding a suitable electronic load that will operate at low output voltages and down to zero load currents. These capabilities are necessary to test DC to DC converters over their full range (from no load to full load output power). Because they can both sink and source current, source measure units (SMUs) are a good choice for testing many smaller DC to DC converters. For example, using two of Keysight's N6782A 2-quadrant SMU modules (installed in our N6705B DC Power Analyzer mainframe) you can test a wide range of DC to DC converters. In addition, we also have PC-based BenchVue software that you can use to set up the hardware and display the measurement results.

### Testing DC to DC efficiency

Typically, the most important DC test for the DC-DC converter is efficiency. This is especially true for battery-powered devices, because efficiency has a direct impact on the life of a device. The efficiency of the converter is the ratio between the output power and the input power. You can easily perform this test using the N6705C DC Power Analyzer and BenchVue software. In this example we have stepped the input voltage from 8 V to 20 V while using an E-load to draw 100 mA from the DC-DC converter output. A formula calculates output power divided by input power (multiplied by 100) to display the efficiency as the input voltage changes (red line at bottom). Markers show that the efficiency changes from 81.5% (at 8 V) to 67.4% (at 20 V).



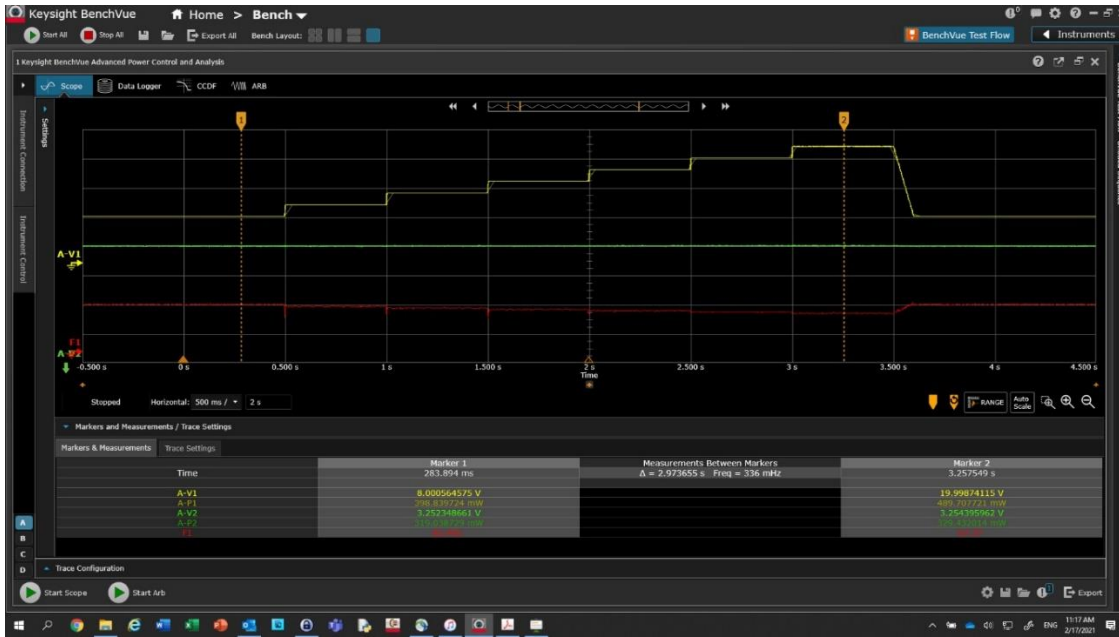

Figure 6.02 – DC to DC converter efficiency test example.

### Testing DC to DC converter load regulation

The load regulation test measures the ability of the DC-DC converter to sustain its specified voltage output when the load current ( $I_{load}$ ) varies at constant input voltage. To execute this test, after powering up the product, slowly vary the output load between the specified minimum and maximum current values. The measured output voltage changes should be within the range specified in the product’s technical specification. The test setup uses the same connections employed for the efficiency test. The following figure shows the output of a 3.3 V DC-DC converter with 15 V applied to the input as the output load varies from 100 mA to 500 mA.

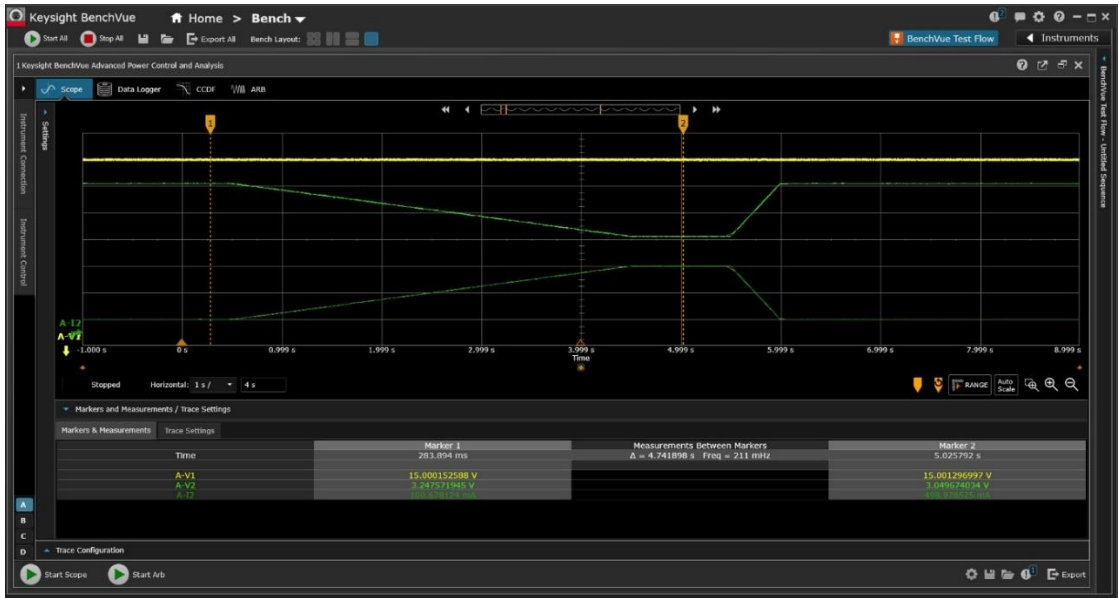

Figure 6.03 – DC to DC converter load regulation test example.

## Testing DC to DC converter line regulation

The line regulation test represents the ability of the DC-DC converter to sustain the specified output voltage while the input voltage varies within a specified range of voltages. To carry out this test, set the input power source to a value within the input range of the product and power up the product. While monitoring the product output voltage, slowly vary the input voltage between the specified minimum and maximum values. The measured output voltage changes should be within the range specified in the product's technical specification. The following figure shows the output of a 3.3 V DC-DC converter with a constant 100 mA load as the input voltage sweeps from 8 V to 20 V.

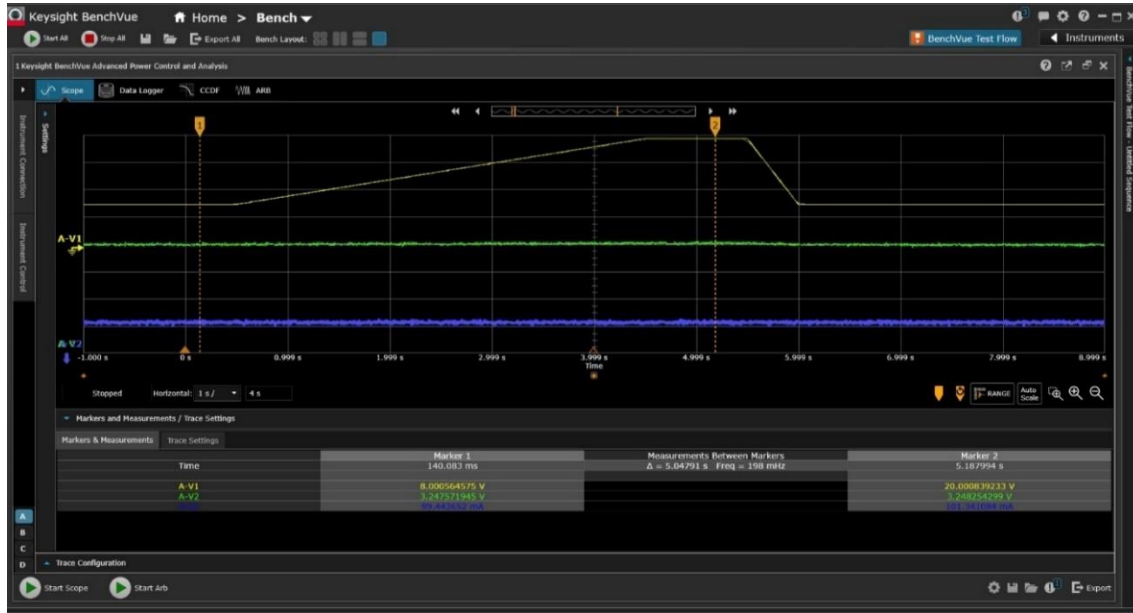

Figure 6.04 – DC to DC converter line regulation test example.

As these examples show, having a modular benchtop instrument (such as the N6705C) that supports both sources and E-loads greatly simplifies performing the various DC to DC converter tests.

## DC to AC Conversion

### Power Inverters

The main use of DC to AC power conversion is to convert the DC voltage supplied by a battery into AC voltage. One application of this process (although not the only one) is to supply power to an AC electric motor. Since virtually all electric vehicles use AC motors, this technology is essential to the modern electric vehicle industry. A power inverter (sometimes just called an inverter) is a circuit or device that converts DC power into AC power. The term inverter typically only applies to circuits and applications involved with power (i.e. large voltages and currents). For small-signal applications, circuits that create an AC signal from a DC input are known as oscillators. The design of DC to AC circuits can be complicated and it is beyond the scope of this handbook. However, a few simple examples can explain some of the basic concepts used in these circuits.

One of the most fundamental conceptual designs for a DC to AC converter uses a transformer with a center tap on the primary inputs (see next section if you are not familiar with transformers).

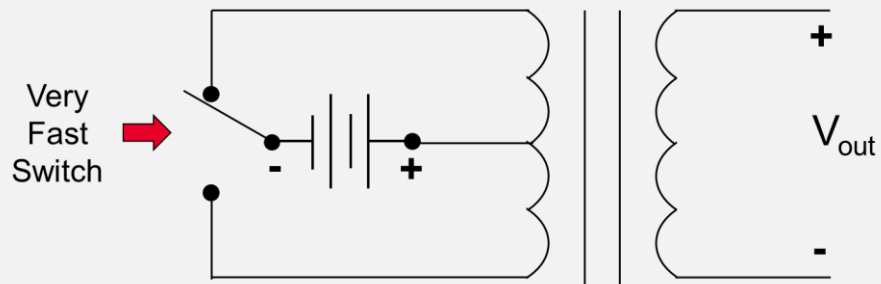

Figure 6.05 – A basic conceptual circuit to convert DC to AC.

By rapidly alternating the DC current between the two primary coils using a very fast switch, you will create an AC current in the secondary coil. Of course, implementing the “switch” in this example at the circuit level requires fast-switching transistors as shown in the following figure.

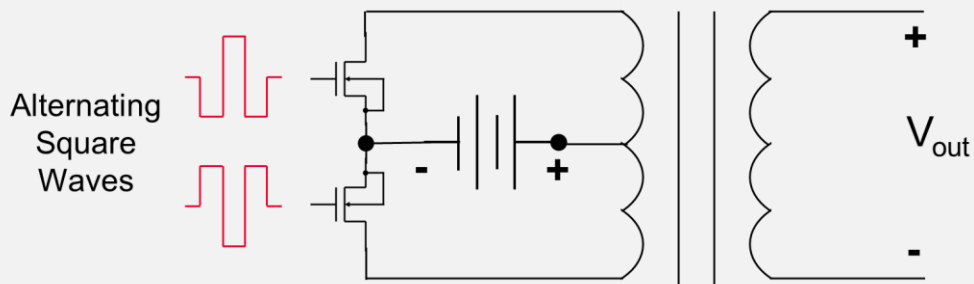

Figure 6.06 – Implementation of fast “switch” using power transistors.

Although the term inverter generically describes any circuit or device that transforms DC power into AC power, there is an important subcategory in this group known as solar inverters. Photovoltaic arrays generate DC power, but many applications require AC power. Therefore, a solar inverter takes solar energy as its input and transforms it into AC power out. We will cover this topic further when we talk about photovoltaic cells.

## Power Transistor Testing

The previous discussion has shown that power inverter circuits use high-power transistors. Of course, traditionally these transistors were silicon-based, but the need to go to higher voltages/currents, achieve faster switching speeds and function at higher temperatures are driving a transition to more advanced materials. Currently silicon-carbide (SiC) is the dominant new technology, but gallium-nitride (GaN) promises even further performance improvements. For more information on testing and characterizing power transistors, please refer to Chapter 9 in Keysight's Parametric Measurement Handbook (publication number 5992-2508EN). You can download the handbook from the following URL: [www.keysight.com/find/parametrichandbook](http://www.keysight.com/find/parametrichandbook).

## AC to AC Conversion

### Transformer basics

The subject of AC to AC conversion inevitably leads to a discussion of transformers, which are essential to power supply design. It is therefore valuable to spend some time understanding transformer basics. A transformer is an electronic component composed of two or more coils of wire wrapped around a ferro-electric material that transfers electrical energy via an alternating magnetic field. Transformers utilize Faraday's law of induction to convert electrical energy (usually voltage) from one value to another. It is important to understand that transformers require an alternating magnetic field in order to function, so they cannot operate on DC electric voltage and currents. As mentioned earlier in this handbook, the primary reason that power transmission uses AC rather than DC voltages and currents is the relative ease by which you can step AC voltages up and down using transformers.

A simple single-phase voltage transformer consists of two sets of wires wound around opposite ends of a magnetic core. We denote one side as the primary winding, and it is usually the side that supplies power (and hence is at a higher voltage). We denote the other side as the secondary winding, and it is usually the side that receives power (and hence is at a lower voltage). For practical reasons relating to the magnetic flux and losses within the core material, the transformer core consists of a series of plates rather than one solid mass. An AC voltage applied to the primary input terminals creates magnetic flux that circulates through the transformer's core. The magnetic flux traveling through the secondary winding induces an AC voltage at the secondary output terminals. Since there is a direct linear relationship between the number of coils in the primary and secondary terminals and the primary and secondary voltages, it is easy to control the ratio between them. The following figure illustrates basic transformer design.

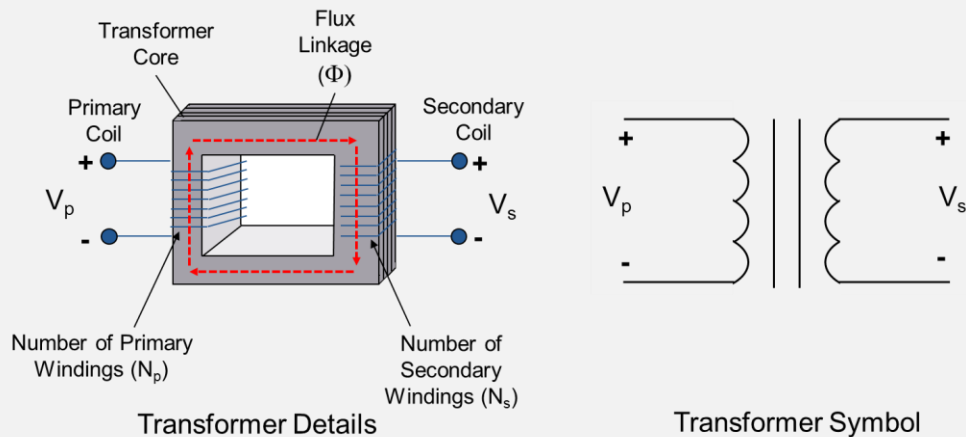

Figure 6.07 – The construction details and circuit diagram for a basic transformer.

By convention we have that:

$V_p$  = Primary Voltage

$V_s$  = Secondary Voltage

$N_p$  = Number of Primary Windings

$N_s$  = Number of Secondary Windings

A nice feature of transformers is that the primary voltage and secondary voltage exist in complete electrical isolation from one another.

If the purpose of the transformer is to increase the primary voltage ( $V_p < V_s$ ), then it is known as a step-up transformer. Conversely, if the purpose of the transformer is to decrease the primary voltage ( $V_p > V_s$ ), then it is known as a step-down transformer. If the purpose of the transformer is to provide electrical isolation, then its design ensures that  $V_p = V_s$  (i.e. a one to one ratio). Assuming an ideal transformer and zero phase difference between the primary and secondary coils, then the transformer turns ratio formula determines the relationship between the primary and secondary voltages as shown in the following formula.

$$\frac{N_p}{N_s} = \frac{V_p}{V_s} = n$$

For example, suppose we have a step down transformer with a turns ratio ( $n$ ) of 4. If we apply an AC signal with an amplitude of 120 V to the primary coil, we can easily calculate the amplitude of the voltage at the secondary coil using this formula.

$$4 = \frac{120}{V_s} \xrightarrow{\text{Solving}} V_s = 30 \text{ V}$$

It is worthwhile to emphasize again that these voltages represent the amplitudes of time-varying signals, as transformers do not work with DC voltages and currents.

While modern transformers are extremely efficient (achieving better than 95% efficiency), all real-world transformers exhibit some power loss at their output. There are essentially two sources of power loss in a transformer. The first is “copper loss” and is due to Ohmic heating of the copper wires used in the transformer windings. The second is “iron loss” and is due to hysteresis of the magnetic molecules in the transformer core as they respond to the alternating magnetic field. The hysteresis of the molecules creates a delay in their response to the alternating magnetic field than in-turn creates frictional heat in the core material. For transformers efficiency by the Greek letter “ $\eta$ ” (eta) and we can express it in terms of the average input and output powers by the following simple formula.

$$\eta = \frac{\overline{P_{out}}}{\overline{P_{in}}} \times 100\%$$

However, we also know that:  $\overline{P_{in}} = \overline{P_{out}} + \text{Copper Loss} + \text{Iron Loss}$

Using the equation for average power of sinusoidal voltage and current waveforms developed in Chapter 2, we can rewrite the efficiency equation in terms of the amplitudes of the output voltage and current, their phase angle difference and the loss terms.

$$\eta = \frac{V_{out} I_{out} \cos \varphi}{V_{out} I_{out} \cos \varphi + P_{Cu} + P_{Fe}} \times 100\%$$

It is possible to have multiple connections or “taps” on both the primary and secondary coils. If you add a connection halfway between the end connections of a coil then you have a center tapped transformer. For example, suppose you have an isolation transformer with a center tap on the secondary coil. You

could connect the primary coil up to a 240 V supply and have two independent 120 V outputs available to drive separate circuits. Another use of taps is for load balancing. Transformers used in electrical power grids often have a series of taps on the primary coil in small increments (~2.5%) to facilitate load balancing. By connecting to different taps on the primary coil you can compensate for both variations in the input (primary) voltage as well as load variations on the output (secondary) voltage. Transformers with different tap configurations are also useful in DC to AC circuit design (see previous section).

While Keysight does not make specific products to test transformers, we do have products that can test certain transformer properties and materials. Typically, some sort of LCR meter performs this testing. For example, the Keysight E4980AL is a cost-effective LCR meter with a maximum frequency of 1 MHz and it can test many transformer parameters. Please refer to Keysight's website for more information.

## AC Sources

In cases where you need to convert AC line voltage to a different AC voltage you need to use an AC power source. Keysight offers two families of AC power sources. The AC6800B series of basic AC sources provide stable, reliable power with models available up to 4000 VA. The 6800C series of performance AC sources provide a complete AC test solution with built in arbitrary waveform generator to simulate many types of power waveforms, at power levels up to 1750 VA. Both families can also produce DC power, either alone or as a DC offset to an AC waveform.



Figure 6.08 – Keysight's family of AC power sources.

The table on the next page summarizes the capabilities of these products.

	AC6800 Series				6800C Series		
	Basic AC Sources				Performance AC Sources		
	AC6801B	AC6802B	AC6803B	AC6804B	6811C	6812C	6813C
Phases	Single-phase						
Max. Output Power	500 VA	1000 VA	2000 VA	4000 VA	375 VA	750 VA	1750 VA
<b>AC Output Mode</b>							
Voltage range	155 Vrms / 310 Vrms				300 Vrms		
Max. rms current	5 A/2.5 A	10 A/5 A	20 A/10 A	40 A/20 A	3.25 A	6.5 A	13 A
Max. peak current	15 A/7.5 A	30 A/15 A	60 A/30 A	120 A/60 A	40 A	40 A	80 A
Frequency	500 Hz				1 kHz		
Measurement	Voltage, current & power						
Transients & advanced measurements	N/A Note: Basic transient capability via Optional Analog card (AC68BALGU)				Includes pre-programmed standard waveforms and transient generation system		
<b>DC Output Mode</b>							
Voltage range	190 V/380 V				425 V		
Max. current	4 A/2 A	8 A/4 A	16 A/8 A	32 A/16 A	2.5 A	5.0 A	10.0 A
Max. instantaneous current	12 A/6 A	24 A/12 A	48 A/24 A	96 A/48 A	40 A	40 A	80 A
Power capacity	400 W	800 W	1600 W	3200 W	285 W	575 W	1350 W
<b>I/O</b>							
	LAN/LXI-Core with remote web interface USB Optional: GPIB				LAN/LXI-Core with remote web interface USB GPIB		



# Chapter 7 – Photovoltaic Power

## Introduction

The ongoing push for “green” energy means that photovoltaic power will only continue to increase in importance into the foreseeable future. This also means that it is extremely important to be able to test the equipment powered by solar arrays thoroughly.

## Photovoltaic Cells

### Photovoltaic cell basics

Photovoltaic cells convert solar energy received as light (photons) into electrical energy. They have two primary application areas:

1. Terrestrial solar power generation (a “clean energy” power source)
2. Powering orbiting satellites or other space vehicles

Solar array definitions and terminology:

- $V_{oc}$  – Open-circuit voltage – no load voltage at the array terminals
- $I_{sc}$  – Short-circuit current – maximum available current flowing out of the array with the array terminals shorted
- $P_m$  – Maximum power output - the voltage and current point where the array can provide maximum power. Also known as the maximum power point (MPP).
- $V_m$  – Voltage at  $P_m$
- $I_m$  – Current at  $P_m$
- $\eta$  – Conversion efficiency of the array - the percentage of power converted from absorbed light to available electrical energy. To calculate this parameter divide the ratio of the watts available at the maximum power point ( $P_m$ ) by the product of the array irradiance (in units of  $W/m^2$ ) and the surface area of the solar array in  $m^2$  under standard test conditions
- FF – Fill Factor; the ratio of the maximum power point power divided by the product of the open circuit voltage ( $V_{oc}$ ) and the short circuit current ( $I_{sc}$ )
- Insolation (Incoming Solar Radiation) – This is the amount of solar energy striking a unit surface area per unit time
- Photovoltaic Cell – The lowest level solar array element. A photovoltaic cell responds to photon irradiation to generate electricity. A cell may consist of multiple photodiode junctions each responding to a range of light wavelengths.
- Solar Module (Segment, String) – A structure composed of a number of photovoltaic cells connected in series, with the number depending on the required voltage level. Available power may range from below 100 to over 1000 Watts. The term “String” can also refer to a series of modules.
- Solar Array – A structure containing multiple modules (segments, strings) used to generate tens and even hundreds of kilowatts
- Solar Panel – Although often used interchangeably with the term Solar Array, it usually means a complete mechanical and electrical integrated structure that includes a solar array

## Modeling solar cell output

When a photovoltaic cell experiences illumination (i.e. converting light into electrical energy), then its IV characteristic will have the following appearance.

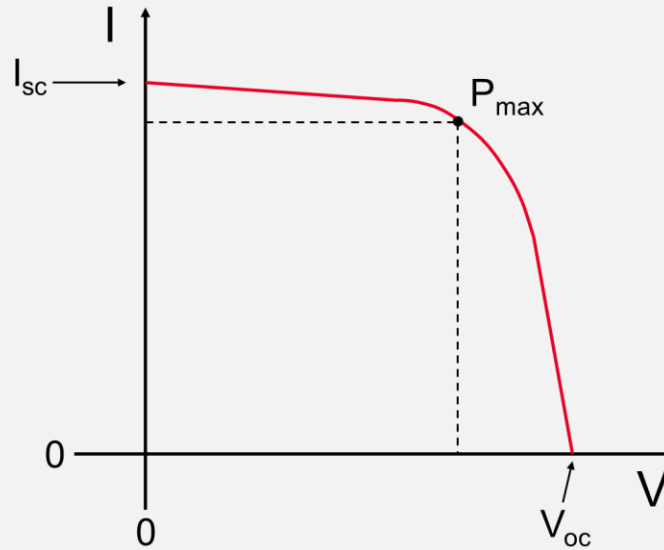

Figure 7.01 – The typical IV characteristic of a photovoltaic cell.

Notice the maximum power point (MPP) of the cell typically occurs in the “knee” of this curve. For obvious reasons, one important goal of power generation using photovoltaic cells is to maintain their operating point as close to the MPP as much as possible (more on this later). The following figure shows the (relatively simple) equivalent circuit model for a photovoltaic cell.

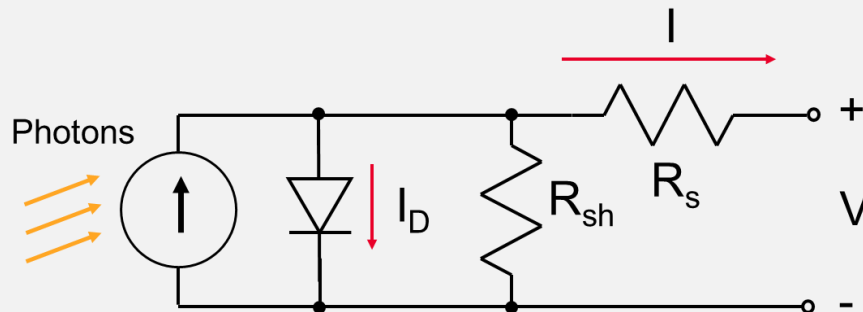

Figure 7.02 – Equivalent circuit model for a photovoltaic cell.

Three key factors affect solar array output. One is the operating scenario, which includes irradiation level, temperature, spin, eclipse and shadow; we will discuss these later. Another factor is the loading conditions, which determines the current and voltage point on the array's IV curve. The third factor spans the inherent characteristics of photovoltaic cells. When you apply illumination to a cell it behaves like a current source in terms of its IV curve and equivalent circuit as shown in the following figure.

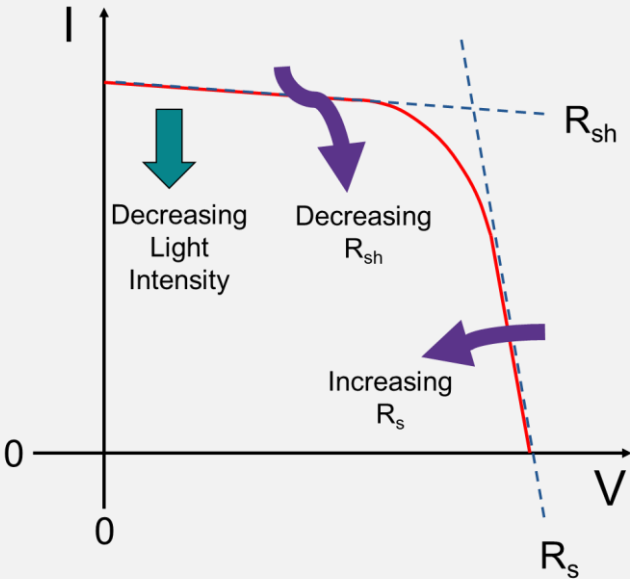

Figure 7.03 – The effects of various parameters on an illuminated photovoltaic cell output.

When in shadow, its IV curve and equivalent circuit are more like those of a diode. By observation, it is clear that the shunt resistance ( $R_{sh}$ ) and series resistance ( $R_s$ ) will have a significant effect on the maximum available output power.

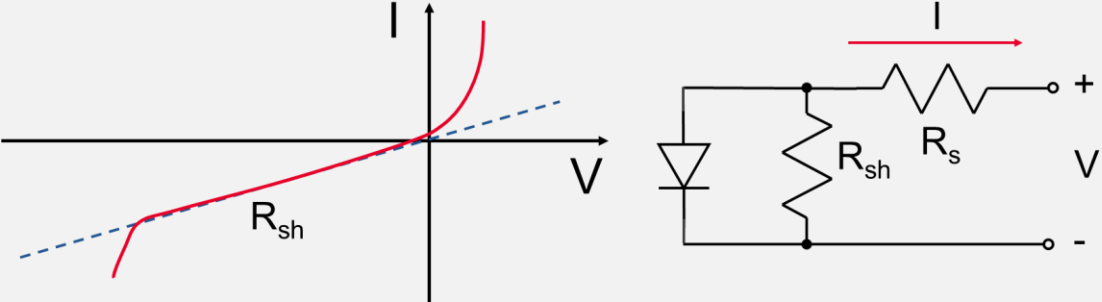

Figure 7.04 – The IV curve and equivalent circuit for a photodiode in the dark.

Using these curves, it is possible to create an accurate simulation of solar cell output. We need four key parameters to create a mathematical model of a solar cell:

$V_{oc}$ : Open-circuit voltage (lower right)

$I_{sc}$ : Short-circuit current (upper left)

$V_{mp}$ : Voltage at the maximum power point

$I_{mp}$ : Current at the maximum power point

It is important to point out that, while this is not the only way to model solar cell, it is the most widely accepted method in use today.

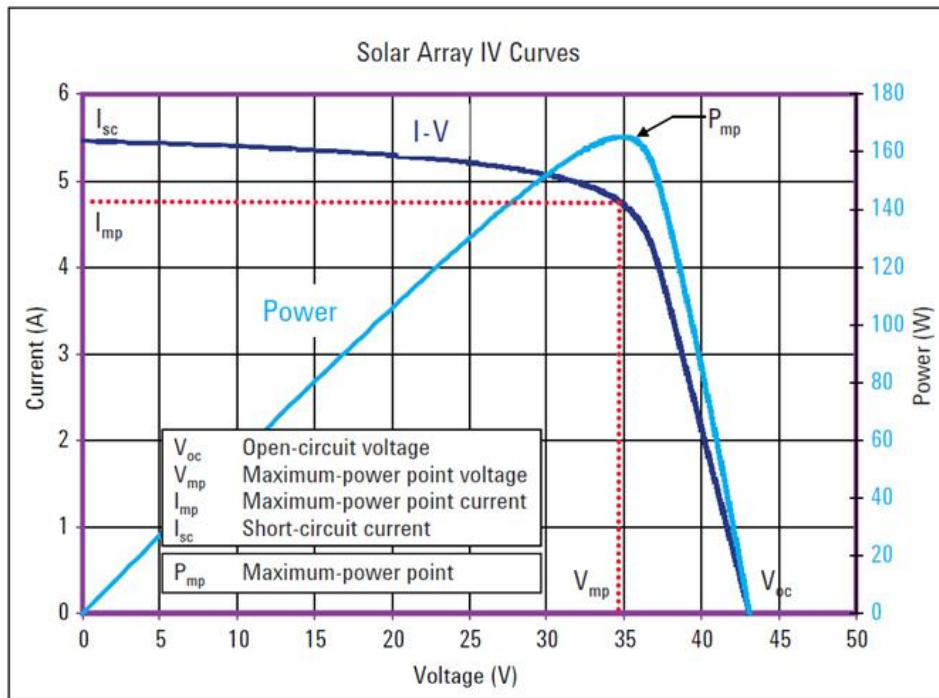

Figure 7.05 – Four variable determine the IV and power curves that you can use to model a solar cell.

### Factors affecting solar cell output

Many factors can affect the power output of a solar array, but the two main factors are irradiation level and temperature.

Not surprisingly, irradiation level has a strong impact on the maximum power available from a solar cell. As the following figure shows, output current varies dramatically with irradiation level (although the change in output voltage is relatively much smaller). The family of power curves shows the change in available power for three different irradiation levels. You can see that as you approach a short or open circuit in the solar cell equivalent circuit model, power diminishes to zero.

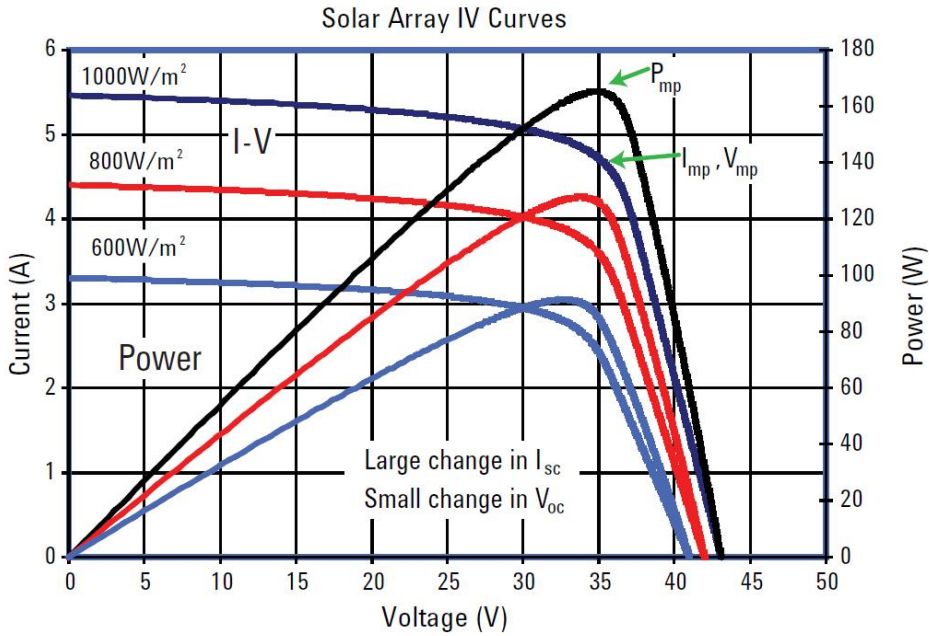

Figure 7.06 – The effect of irradiation level on solar cell power output.

The other major factor that impacts solar cell output power is temperature. As solar cells and arrays undergo temperature fluctuations, output power will vary significantly. The following figure shows the I-V and power curves at +25 °C and +90 °C as labeled on the respective traces under a constant irradiation level.

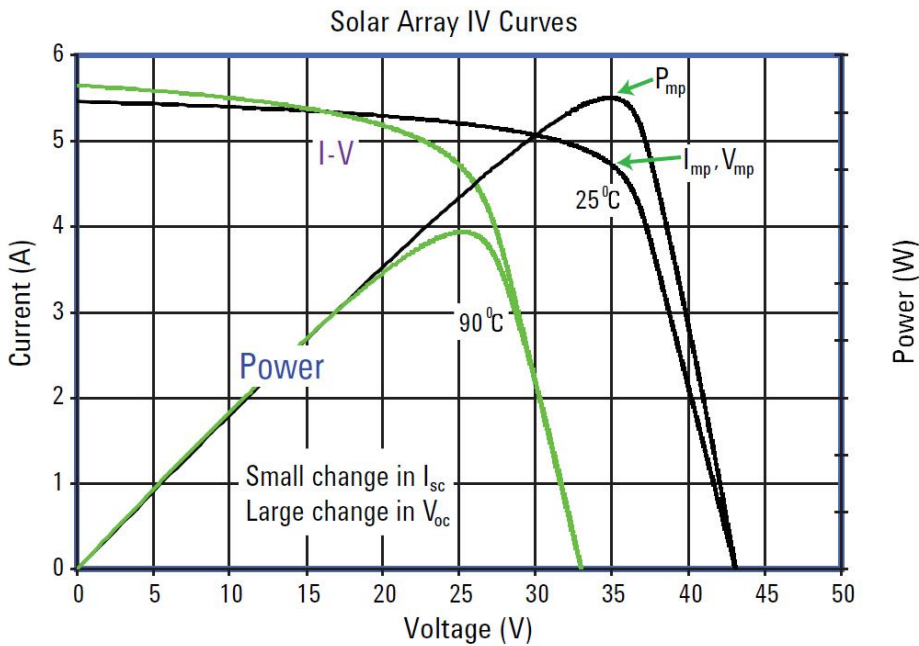

Figure 7.07 – The effect of temperature on solar cell power output.

This figure illustrates an important contrast between the effects of irradiation and temperature. Whereas decreasing irradiation primarily decreases current with little impact on voltage, increasing temperature primarily decreases voltage with little impact on current. These relationships have some important engineering considerations, since power losses in cabling and wiring harnesses exhibit an  $I^2 \times R$  relationship. As a result, changes in current due to irradiation level variations generally have a greater impact on overall power efficiency than do voltage variations caused by temperature fluctuations.

## Ground Testing of Solar Arrays for Satellites

### Why perform ground testing?

Satellites comprise some of the world’s most delicate and expensive electronic devices. Because most take a one-way trip into space, they require thorough testing on the ground before launch. Within the complement of electronic ground support equipment (EGSE), a typical test system contains two major elements: The instrumentation that tests the various electronic subsystems; and one or more power sources for the subsystems. The power sources must accurately simulate the behavior of solar arrays that face widely varied operating conditions in space.

During testing it is almost impossible to use actual solar arrays to provide power. There are two obvious reasons for this. There is no direct sunlight in a test bay, and testing outdoors is not practical. However, there are two additional reasons that are crucial to accurate testing: repeatability and controllability. It is extremely important to have test equipment that can simulate the effects of varying operating conditions—light intensity, temperature, shadow, eclipse—at multiple operating points and achieve consistent results.

### Solar array considerations for satellites

Achieving maximum output from a solar array can be complex given the range of effects that will diminish available power. In addition to irradiation level and temperature, satellite solar arrays must contend with several important orbital conditions including spin, eclipse and shadow. These effects make the simulation of satellite solar cell arrays much more difficult than for their terrestrial counterparts.

Assuming the satellite has a semi-cylindrical shape (common for many satellites) with multiple solar array panels attached to its exterior, then as the satellite spins each solar panel will experience changes in irradiation and temperature that depend on the rate of rotation. The following figure illustrates this situation.

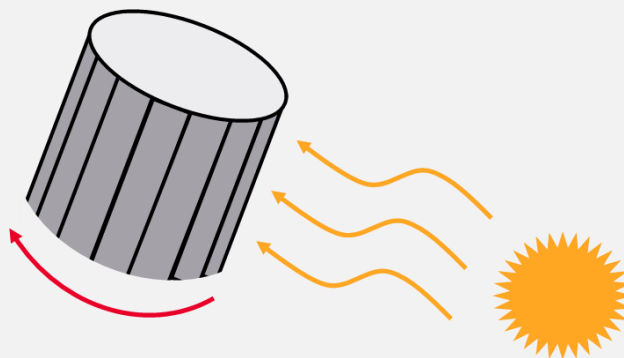

Figure 7.08 – Changes in array segment irradiation and temperature depend on the rate of satellite rotation.

The following figure plots the rising and falling cycles of output that occur as a set of four panels enters and exits a period of sunlight. The actual available power depends on four key factors: the number of panels and their size; the spin rate; the ongoing heating and cooling experienced by each panel; and the irradiation level, which depends on factors such as orbit plane (e.g., relative angle to the sun), distance from the sun and relative motion relative to the sun (i.e., approaching or receding).

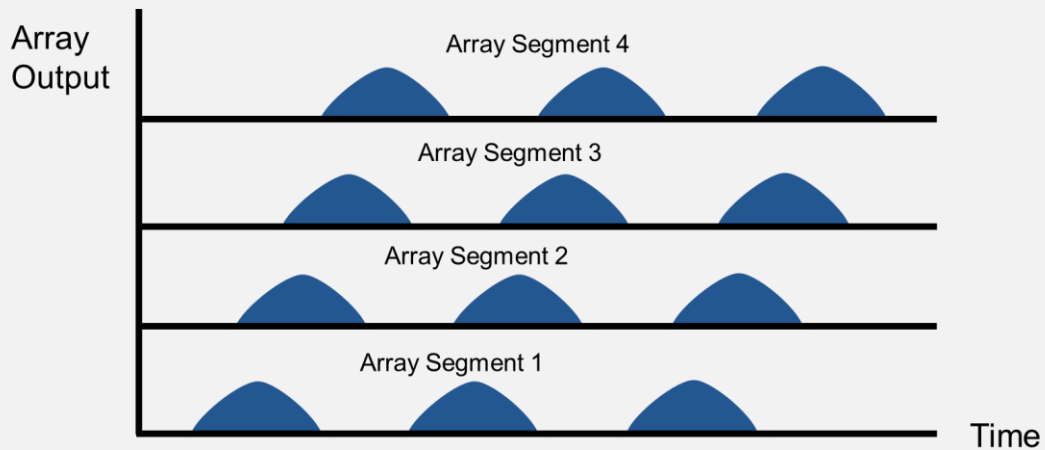

Figure 7.09 – Available output power from each panel rises and falls as the satellite spins.

A satellite-based solar array is in eclipse whenever the Earth, Moon or other celestial body is between it and the Sun. The duration of the eclipse depends on the plane and radius of the satellite’s orbit. The rate at which a satellite enters and exits eclipse depends on its orbital velocity. The following figure shows the typical shape of an array’s output during penumbra, umbra and full-sun conditions.

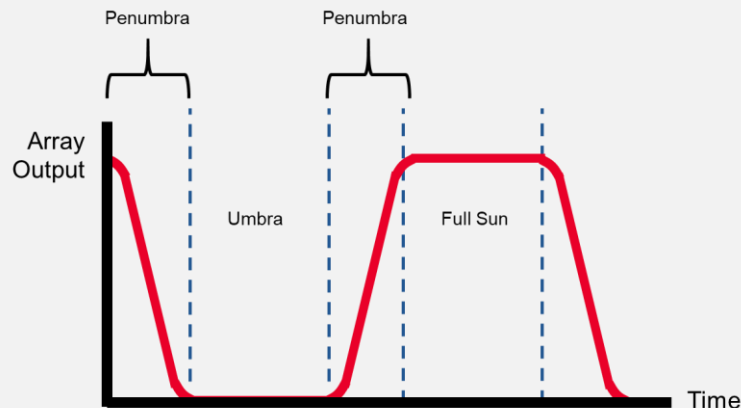

Figure 7.10 – Available output power varies as the satellite enters, transits, and exits darkness and then re-enters full-sun condition.

Dealing with eclipse conditions requires the use of solar arrays and batteries. The batteries provide power while the satellite is in eclipse and they recharge when the satellite is in sunlight. To ensure continuous power to the spacecraft systems, the arrays, voltage regulators and charging circuits need to work flawlessly and in perfect harmony. In addition, you also need to consider the temperature effects

due to eclipse. Since cold arrays are more efficient than warm arrays, each solar panel is at its maximum power generation capacity as it emerges from eclipse and re-enters full sun conditions. Its efficiency will therefore decline during the time it spends in full sunlight.

A solar array is in shadow when any part of it is not receiving sunlight. Obviously, any shadowed cells reduce the overall power available from a solar array. However, it is important to understand that the extent of the reduction depends on the actual construction (serial or parallel connection) of the cells and/or segments in an array. The equivalent circuit of a photovoltaic cell provides the best insight into understanding the electrical behavior of cells in shadow. As the following figure shows, adding a bypass diode to each cell improves the performance of the overall array when parts of it are in shadow.

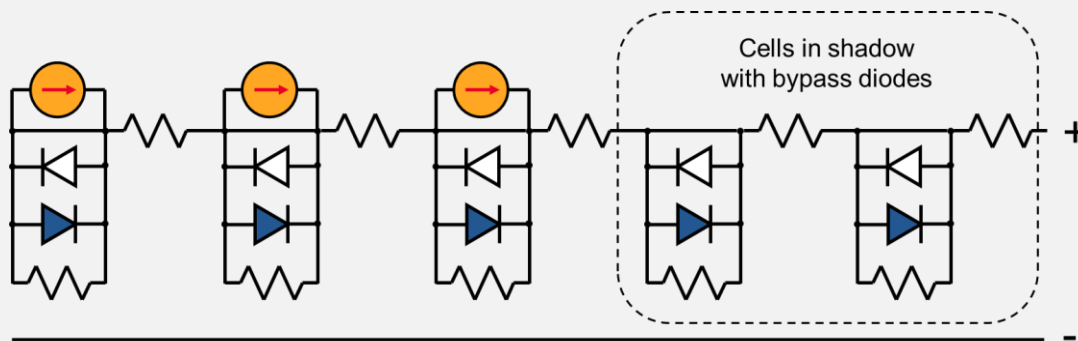

Figure 7.11 – Adding bypass diodes to the cells improves performance when individual cells are in shadow.

One complication of using bypass diodes is that series and parallel combinations of multiple cells in shadow can create IV curves with shapes that are difficult to simulate as shown in the following figure.

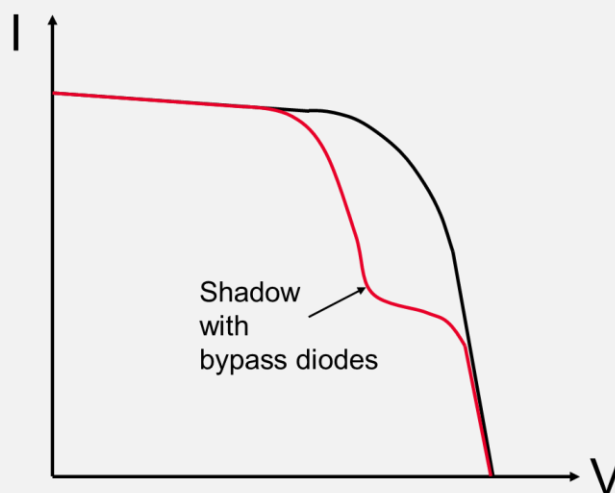

Figure 7.12 – Shadow effects can create IV curves that are difficult to simulate.



## Solar array simulation

All of the factors discussed in the previous section can act to limit the maximum output power available from a solar array. This is the key challenge for satellite solar array simulation: realistically and reliably reproducing these effects to ensure meaningful test results. However, there is an additional factor that you must also consider: the type of bus regulation used within the satellite. There are four typical satellite bus-regulation topologies: direct connection, series switching, sequential shunt switching and maximum peak power tracking (MPPT). Today, sequential shunt switching and MPPT dominate.

In sequential shunt switching the control process is relatively simple. It either directs current from each solar array segment to the load when needed or shorts the output of a segment when not needed. The number of active shunt switches can vary from none to all, which can have a significant effect on cooling in the solar array simulator. The output stage of a solar array simulator uses a linear regulator to achieve the required performance. When a shunt switch is on, the simulator will dissipate all of the power that the bus would have received. Thus, effective cooling is essential whenever all of the shunt switches are simultaneously shorted. In addition, shunt switching present another challenge to realistic simulation. Unlike voltage pulse width modulation (PWM), which regulates by averaging the modulation pulse with an LC filter, shunt switching modulates current to achieve regulation. As a result, any solar array simulator must be able to handle rapid current transients.

As its name suggests, the MPPT technique attempts to continuously and dynamically seek an array's maximum power point. This is a complex technique that uses two control loops to regulate power: a slow MPPT loop and a fast voltage loop within one or more DC-to-DC converters. It also increases overall efficiency by reducing the amount of power lost through heat dissipation (an effect commonly seen in sequential shunt switching). For MPPT systems, a key need is for the solar array simulator to maintain operation along the programmed IV curve while the tracking circuitry searches for the maximum power point. The solar array simulator also has to be able to enable verification of power efficiency and MPPT accuracy.

### Can programmable power supplies simulate solar arrays?

Before proceeding further, a reasonable question to ask is: Why do you need specialized instrument to simulate a solar array when standard programmable power supplies should be able to do the same function? There are actually three good reasons why a solar array simulator (SAS) is the best choice for this application, and they are all explained below.

The first reason that programmable power supplies are not optimal for solar array simulation has to do with output capacitance. Designers of general-purpose power supplies want them to act as voltage sources that maintain a stable output under a variety of load conditions. While this behavior is ideal for a wide range of applications, it is not so good for solar array simulation. The reason is that solar panels are current sources, so their design needs to include the ability to operate as a current source. Current sources typically have high output impedance and low output capacitance, and these characteristics provide two benefits:

1. Fast switching speeds for better simulations and shorter test times
2. Enhanced protection of the DUT by reducing the power stored in the circuit (smaller short-circuit current spikes)

The second reason that programmable power supplies are not optimal for solar array simulation has to do with output flexibility. Conventional rectangular power supplies (see Chapter 4) adjust output voltage and current across straight line values, whereas solar array panels have exponential shaped IV curves. Therefore, to truly emulate solar array behavior a SAS must be capable of making similarly shaped curves. In addition, an SAS also has to be capable of making rapid curve changes to realistically simulate varying irradiation levels, changes in temperature, as well as the effects of spin, eclipse and shadow.

The third and final reason that programmable power supplies are not suitable for solar array simulation has to do with their ability to protect DUTs from damage. Since satellites are delicate (and expensive) instruments that voltage and current spikes can easily damage, instruments used during their ground testing must provide extensive levels of protection. The typical over-voltage protection (OVP) and over-current protection (OCP) circuits found in conventional power supplies are not sufficient to guarantee sensitive satellite circuitry will not experience transient current spikes or protect internal components from harmful power levels.

In summary, a conventional programmable power supply cannot match the features found on a well-designed SAS, which provides lower output capacitance, greater solar output simulation flexibility and better protection for the DUT. These capabilities translate to better simulations, shorter test times and greater peace of mind about the survival of the satellite during terrestrial testing.

## Keysight Solar Array Simulator Solutions

### Creating an Optimal Solution

Keysight Technologies is the leading manufacturer of solar array simulators and SAS solutions, which are now in their fourth generation. We created the first generation by adding simple software to a standard DC supply. Applying the lessons learned from that experience, the succeeding generation were the purpose-built E4350A family, the E4350B family and today's E4360A family. Along the way, we have incorporated five key ideas that address important consideration in the definition and selection of an SAS: outputs ratings and performance specification, protection features physical size and power density, uptime, and system-level considerations.



Figure 7.13 – The Keysight E4360A modular solar array simulator can accurately simulate the I-V curves of different arrays under various operational conditions.

Output ratings and performance specifications – This is all about current, voltage, power and shut-switching speed. A wider variety of choices make it easier to select the best combination of power levels, shunt speeds, etc. to meet the needs of a specific satellite design.

Protection features – As noted earlier, an SAS need to include more than the OVP and OCP capabilities built into conventional power supplies. For example, Keysight's SAS solutions provide the following layers of extra protection:

- Programmable soft limits for OVP and OCP. This helps protect against operator error when typing in values.
- Gross current limiting to cut the transient current spikes.
- Over-switching protection, which protects internal components against power dissipation if they cross the switching frequency threshold.
- A programmable remote-inhibit function that validates user-defined shutdown procedures.

Size and power density – In many cases, it is important to minimize the physical footprint of the test system while maximizing the per-instrument power density. An SAS with a compact form factor and a modular architecture makes it possible to fit more power (and more simulation channels) into less space. This is especially important when space is at a premium within a system rack and inside a high bay facility as shown in the following figure.



Figure 7.14 – This rack uses 12 Keysight E4360A units to supply 24 channels for simulation.

Uptime – Statistical quantities such as mean time between failures (MTBF) are a baseline for reliability. Attributes such as modularity and scalability do more than enhance flexibility and reusability: they also improve system uptime. As an example, modularity makes it possible to swap out a single power module when maintenance, calibration or repair is necessary. Scalability makes it easy to expand, reconfigure or repurpose a system or console when needed.

System-level considerations – An SAS is typically part of a larger rack-based system. In that context, factors such as configurability and serviceability become important considerations. A good starting point is ease of configuration for initial use. In a single-purpose system, modularity enables future reuse in new systems. For multi-purpose systems, dynamic reconfiguration helps ensure faster changeover. In either case, interconnect features such as barrier-block termination coupled with relays are present to help simplify reconfiguration. To minimize downtime, instrument or system service should require minutes rather than hours or days. A modular SAS should make it easy to remove and replace individual power modules. The barrier-block/rely interconnect scheme mentioned above simplifies self-test procedures by supporting rapid disconnection and reconnection.

## Summary and Conclusions

The challenges of accurately simulating the effects of operational conditions (irradiation level, temperature, spin, eclipse and shadow) preclude the use of conventional power supplies for solar array test. Related factors include output capacitance, output flexibility and DUT protection. The latter point is especially important in satellite testing. A dedicated SAS goes beyond OVP and OCP to provide additional layers of protection such as programmable soft limits (for OVP and OCP), gross current limiting, over-switching protection and programmable remote-inhibit functionality.

A modular, scalable and purpose-built SAS such as the Keysight E4360A family makes it possible to accurately and efficiently simulate the complex behavior of one or more photovoltaic cells and solar arrays. The E4360A interface is based on four parameter that enable efficient generation of the required IV curve: open-circuit voltage, short-circuit current, voltage at the maximum power point and current at the maximum power point ( $V_{oc}$ ,  $I_{sc}$ ,  $V_{mp}$ , and  $I_{mp}$  respectively). The instruments' "list mode" enables creation of user-generated curves and allows rapid transitions from curve to curve to simulate (for example) the stages of eclipse.

## Chapter 8 – Power Supply Software

### Instrument Control Basics

Before beginning a discussion of some of the different software options available to control power supplies, it is important to understand the basics of instrument control. When controlling any instrument you have three primary choices to make:

1. Which physical communication medium to use
2. What I/O protocol to use
3. What software to use on your controller (PC or other)

### Physical Communication Medium

There are a number of choices for the physical medium by which you communicate with one or more instruments. Many applications still utilize the long-established General Purpose Interface Bus (GPIB), although its use is gradually decreasing in favor of more recent computer-based buses: RS-232, Universal Serial Bus (USB) and Local Area Network (LAN aka Ethernet). The following list describes each of them in detail.

**GPIB** – Despite its age (originating in the 1970s), the GPIB (or IEEE 488) bus remains very popular for instrument control. It supports up to fifteen instruments, and it allows data flow between instruments at speeds suitable for even the slowest instrument.

**RS-232** – The Recommended Standard 232 (RS-232) bus is a serial data bus that originated to allow a PC to communicate with peripheral devices and exchange data with them. It most often uses a 9-pin DB-9 style connector, often just denoted as a “D type connector”. However, the newer USB standard has mostly supplanted the RS-232 bus.

**USB** – The Universal Serial Bus (USB) standard provides the specifications for the hardware and software protocols to connect computers to each other and to other equipment. There have been several generations of USB standards, with the most recent being USB4. There are a variety of supported physical connection standards for USB, including standard, mini and micro.

**LAN** – This is something of a misnomer as it really refers to the Ethernet standard, which is what networks use to implement a LAN. Modern Ethernet standards can support data transfer speeds of hundreds of Gigabits per second. The High-Speed LAN Instrument Protocol (HiSLIP) is a TCP/IP based protocol designed to support test and measurement instruments via a LAN connection. Its purpose was to replace the older VXI-11 and correct some of its flaws. Instruments typically use HiSLIP with a library that implements the VISA API (see next section).

## I/O Protocols

Keysight bundles its I/O offerings into a single product called the Keysight IO Libraries Suite. It contains everything you need to initiate controlling your instrument. Each instrument and I/O interface that you purchase from Keysight includes the IO Libraries Suite.

An I/O library is software that runs on your computer to establish communication with an instrument. This communication could be over GPIB, USB, LAN, RS-232, VXI, or some other physical medium. If you write software, or use prewritten software, to control your instruments they will probably use one of the I/O libraries mentioned below. Instrument drivers, which provide a higher-level interface to the instrument, use I/O libraries internally to send and receive information from the instrument.

The Virtual Instrument Systems Architecture (VISA) library is the industry standard for instrument control and the IVI Foundation now maintains it. A program written to work with the VISA library will work with implementations of VISA from other vendors. You can use it from any program that can call arbitrary Windows DLLs, such as:

- Keysight VEE
- C/C++
- MathWorks MATLAB
- Microsoft Visual Basic 6
- Microsoft Visual Studio .Net (using Visual Basic, Managed C++ or C#)
- National Instruments LABVIEW
- National Instruments LabWindows/CVI

VISA provides complete access to GPIB, LAN, USB, RS-232, VXI message-based, and VXI register-based products.

The VISA-COM library is a Component Object Model (COM) interface for I/O originally developed as a companion to the VISA specification, and the IVI Foundation also maintains it. A program designed to use the VISA COM Global Resource Manager will work with any vendors implementation of VISA COM. VISA COM works best in standard object-oriented ADE's that support COM directly, or through some interoperability mechanism. These environments include:

- Keysight VEE
- Microsoft Excel using VBA
- Microsoft Visual Basic 6
- Microsoft Visual Studio .Net (using Visual Basic, Managed C++ or C#)
- Other environments may work with VISA COM, but there are I/O libraries that work more seamlessly (E.g. VISA). VISA-COM does not support VXI devices.

The Standard Instrument Control Library (SICL) library provides very complete and flexible control of instruments. However, Keysight implemented this API and primarily supports it. C and C++ allow you to make optimal use of SICL, but you can also use SICL with Visual Basic and other environments that have the ability to call arbitrary Windows DLLs (see VISA description for examples). SICL provides complete access to GPIB, LAN, USB, RS-232, VXI message-based, and VXI register-based products.

Because SICL is a proprietary library, we recommend that you do all new development using VISA or VISA COM.

The Keysight 488 library is Keysight's implementation of the National Instruments NI-488.2 protocol. With Keysight 488, you can reuse existing NI-488.2 programs while using Keysight GPIB interfaces. Keysight 488 works seamlessly with NI-488.2 and you can use both Keysight and NI GPIB cards interchangeably. Like VISA and SICL, Keysight 488 works in any environment that can call arbitrary Windows DLLs. Keysight 488, like NI-488.2, also only works with GPIB interfaces. Because Keysight 488, and National Instruments NI-488.2, is a proprietary library, we recommend that you do all new development using VISA or VISA COM. The following figure summarizes the components necessary for computer-based instrument control.

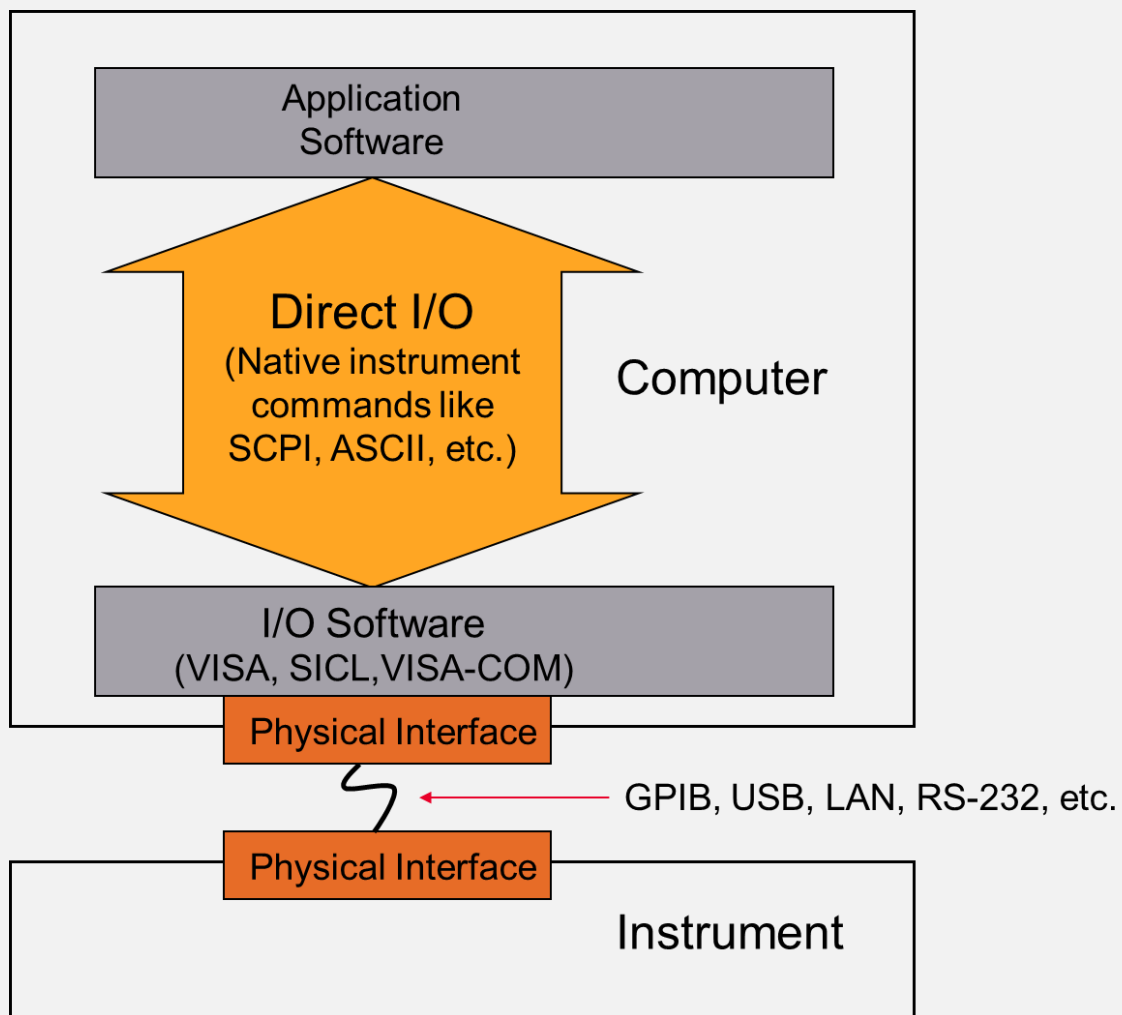

Figure 8.01 – The basic components of computer based instrument control.

## What is an instrument driver?

If you are using a computer to control one or more instruments then it has some sort of operating system (Windows, Linux, etc.) and application development environment (ADE) such as Visual Studio.NET. A computer language (C#, Python, etc.) sends program commands to the instrument, and those commands pass on to the IO software, which then passes them via a physical interface to the instrument's internal processor. While this process works OK for simple applications, as application complexity increases using direct I/O can become difficult and time consuming since the programmer must have memorized or look up the direct I/O SCPI commands for the particular instrument they are programming.

An instrument driver is a high-level, instrument-specific or instrument class specific piece of software intended to solve these issues. Instrument drivers facilitate instrument programming by guiding the user through all of the necessary programming steps. An instrument driver can take many forms. For example, a driver could be a list that pops up when you hit the next "dot" in Visual Basic, or it could be as elaborate as a "panel driver" that displays a virtual front panel on the screen of your computer to help you set up the instrument. Drivers typically support most (but not all) of an instrument's command set. This is simply due to the fact that complex instruments can have hundreds of commands and functions, most of which are rarely employed by users.

There are three basic generations of drivers: Proprietary T&M drivers, Traditional T&M drivers and Component PC drivers. These represent the past, present, and future of driver technology. In the past, instrument drivers were custom designed to function with a vendor's own application development environment (ADE). A considerable body of legacy application programs uses these proprietary drivers, but for new development, engineers today have better choices. The following figure summarizes the various instrument driver families.

Instrument Driver Families					
Component PC (based on PC standards)	Traditional T&M (based on T&M standards)			Proprietary T&M (specific to one language)	
IVI-COM	IVI-C (via NI)	WIN <i>VXIplug&amp;play</i>	LabWindows/ CVI Plug&Play	VEE Panel Drivers	LabView Plug&Play Drivers ( <i>VXIplug&amp;play</i> GWN)

Figure 8.02 – The three generations of instrument drivers, which represent varying degrees of programming language independence.



The “IVI” term shown in this figure (and discussed earlier) refers to classes of drivers defined and supported by the Interchangeable Virtual Instrument (IVI) Foundation. The foundation comprises end-user test engineers, equipment manufacturers and system integrators with many years of experience building test systems. An IVI class driver allows you to program any instrument in that class in the same way (regardless of manufacturer). An IVI Class Driver (IVI-C Class or IVI-COM Class) can refer to both the specification and any specific driver that implements it.

When you need to accelerate test system design and deployment, Keysight recommends the new IVI-COM driver and the VXIplug&play WIN32 driver for instrument control. The only Component PC driver built on PC standard architecture is the new IVI-COM driver. Keysight (along with other instrument companies) are leading this standard. A component driver built on COM works in all popular PC languages and most T&M languages, uses the most popular types of I/O, functions in the latest .NET technologies and is backward-compatible.

## Keysight Command Expert

### What is Command Expert?

Keysight provides a free software utility, Command Expert, that greatly simplifies the task of controlling instruments from a PC. Command Expert combines instrument commands, documentation, syntax checking and command execution into one simple interface. Command Expert works with instruments that use Standard Commands for Programmable Instrumentation (SCPI), IVI-C, or IVI-COM drivers. Command expert’s integrated interface allows you do to all of the following quickly and easily:

- Find instrument commands
- View complete command documentation
- Verify command syntax
- Build instrument command sequences
- Execute instrument command sequences
- Integrate sequences into PC application environments

If you are using the Keysight IO Libraries Suite discussed in the previous section, then you can use Command Expert to quickly connect and configure any instrument it discovers. The search capability displays a list of commands ranked by relevance. You can also select the results it displays to view detailed documentation. Examples provide sequences of commands that you can use directly in Command Expert and the PC application. These examples provide the building blocks for developing the sequences for the specific needs of each user. Simply enter the search term(s) and see the list of associated examples. Filters can narrow down the list by instrument, application and/or command type. Also included are SCPI, IVI-C, and IVI-COM examples.

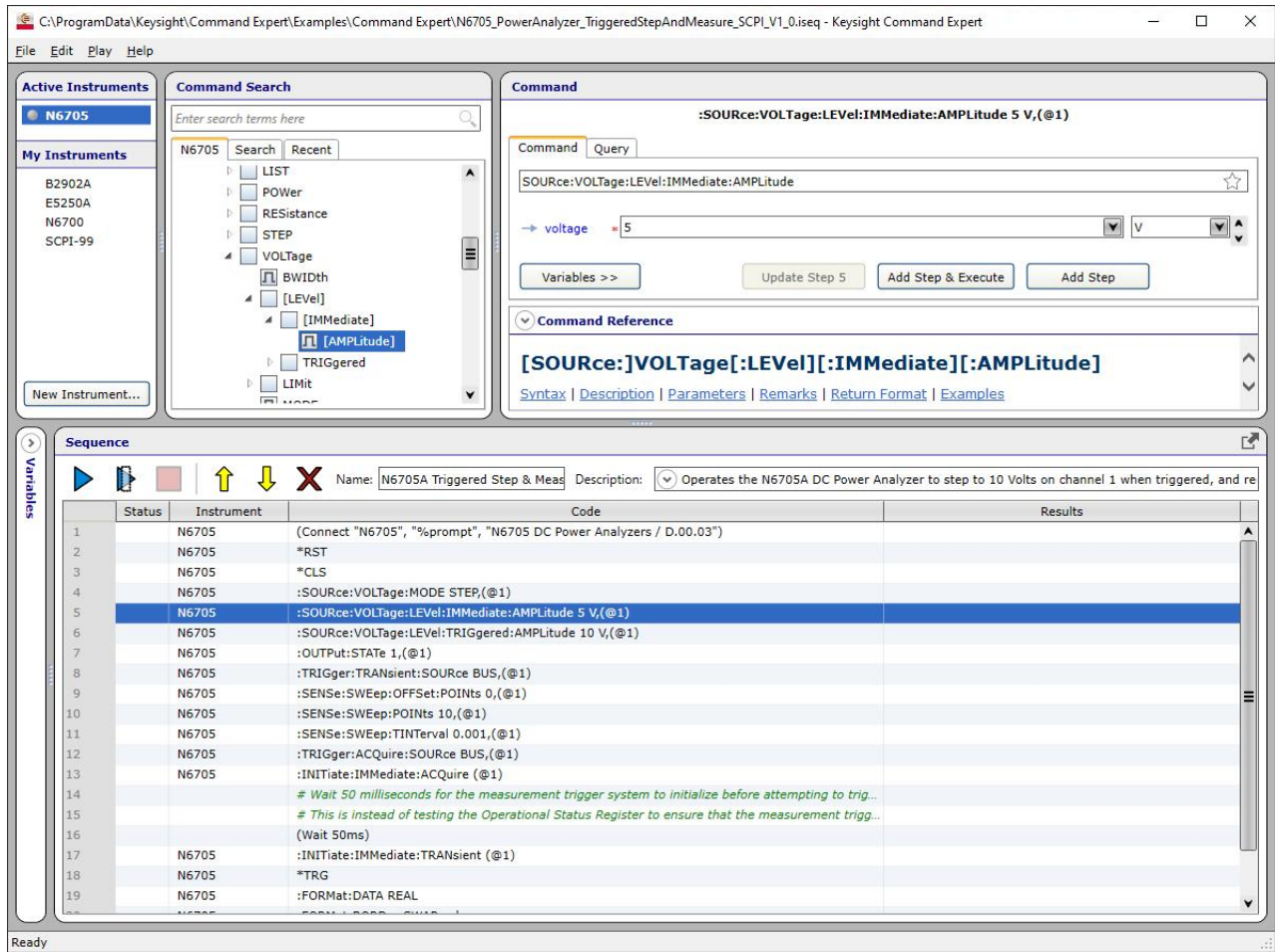

Figure 8.03 – Instrument control example using Command Expert.

## Exporting into other programming environments

Once you have created and debugged a in Command Expert, you can easily export it into a variety of programming environments through simple copy/paste operations. The supported export formats include:

- SCPI
- C# with calls to SCPI.NET Drivers
- VB.NET with calls to SCPI.NET Drivers
- Python with calls to PyVISA
- C/C++ with calls to VISA Formatted I/O
- MATLAB with calls to Instrument Control Toolbox
- Comma-separate values (for Excel)

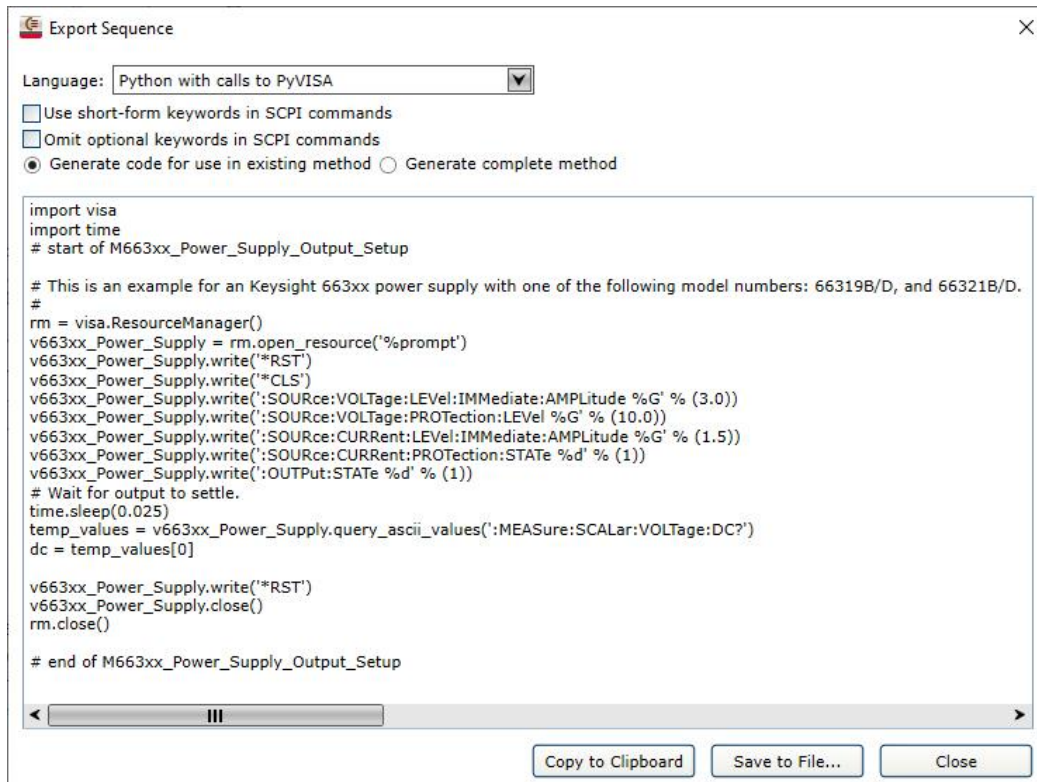

Figure 8.04 – Example showing code export from Command Expert into Python.

## Keysight BenchVue

The BenchVue software platform is a no-cost software framework that allows you to access and use all of the BenchVue apps in one convenient location. It has an Apps tab that allows you to easily view, download and install apps and enable free trials. It also has a demo mode that permits you to try out new and different apps without the need to have the actual instruments on your bench. For convenience, BenchVue allows you to quickly find all the documentation for your Keysight instruments in the Library tab, and all Apps include a subscription to KeysightCare software support.

### What does BenchVue provide?

Keysight PC-based BenchVue software eliminates many of the issues faced by benchtop instrument users. BenchVue makes it easy to connect instruments, control instruments, and automate test sequences, allowing you to quickly move past the test development phase and access results faster. A large selection of applications is available for each instrument family (including of course power supplies and electronic loads) that facilitate measurement setup and data analysis. In addition, integrated Test Flow apps drastically shorten automated program development times and help streamline your workflow. The BenchVue apps can help you to:

- Configure the most commonly used controls and measurements from instruments
- Visualize multiple measurements simultaneously
- Easily log and export data and images in a few clicks for faster analysis
- Quickly create automated test sequences with minimal instrument knowledge
- Access deeper instrument controls and solutions

BenchVue can also help with data analysis, either through its built-in capabilities or by using its ability to export data into other tools (Excel, etc.). Finally, BenchVue’s main benefit is that it greatly reduces the learning curve when programming new instruments due to its common look and feel.

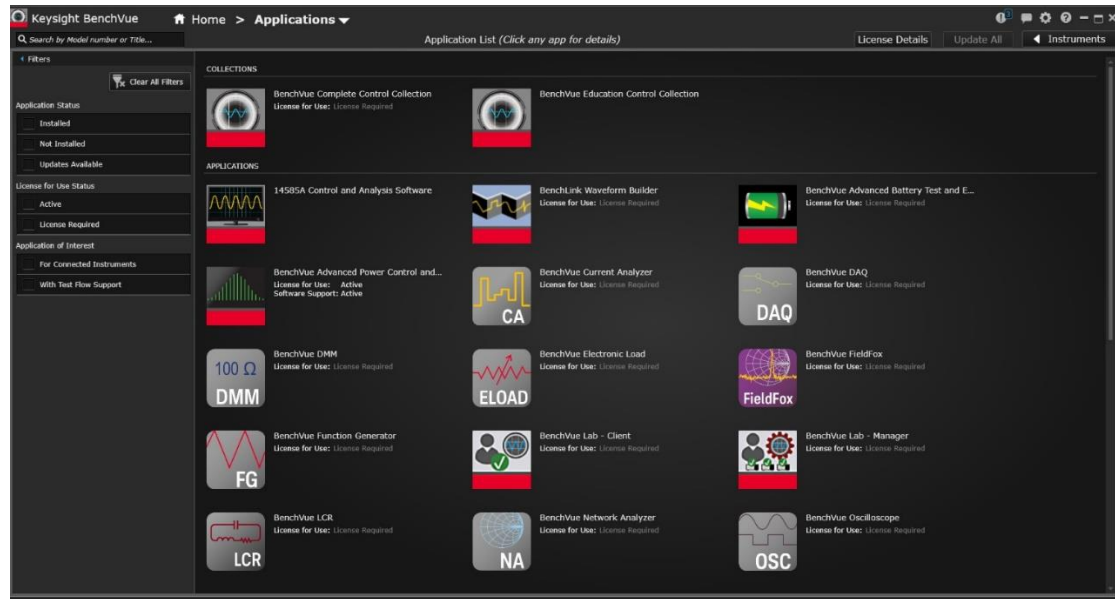

Figure 8.05 – Keysight BenchVue provides a common user interface for a wide variety of application software.

## Advanced Power Control and Analysis Software

The Advanced Power Control and Analysis Software is an available application bundle for BenchVue that allows you to control and analyze voltage and current measurements from up to four series N6700, N7900 or RP7900 instruments. It replaces the older Keysight 14585A software, which Keysight will no longer sell after June 1, 2021.

### Key Features

- PathWave BenchVue BV9200B Advanced Power Control and Analysis Software Supports up to four instruments
- Easily track and record your power supply outputs to understand events impact on power usage
- Graphically configure three modes of analysis: scope (short-term waveform capture), data logger (long-term waveform capture), and CCDF (statistical analysis)
- Easily create complex waveforms to stimulate or load down a DUT by inputting a formula, choosing from built-in, or importing waveform data
- Export data for additional analysis
- Integrate software functions into your programming environment via application programming interface (API)
- Control and analyze data from up to four supported power supplies or 16 outputs (N6700 series)
- Supported instruments include any combination of N6705 DC Power Analyzer, N7900 Series Advanced Power System, and RP7900 Series Regenerative Power System

The Advanced Power Control and Analysis Software all of the features familiar to users of the 14585A software such as arbitrary waveform generation as shown in the following figure.

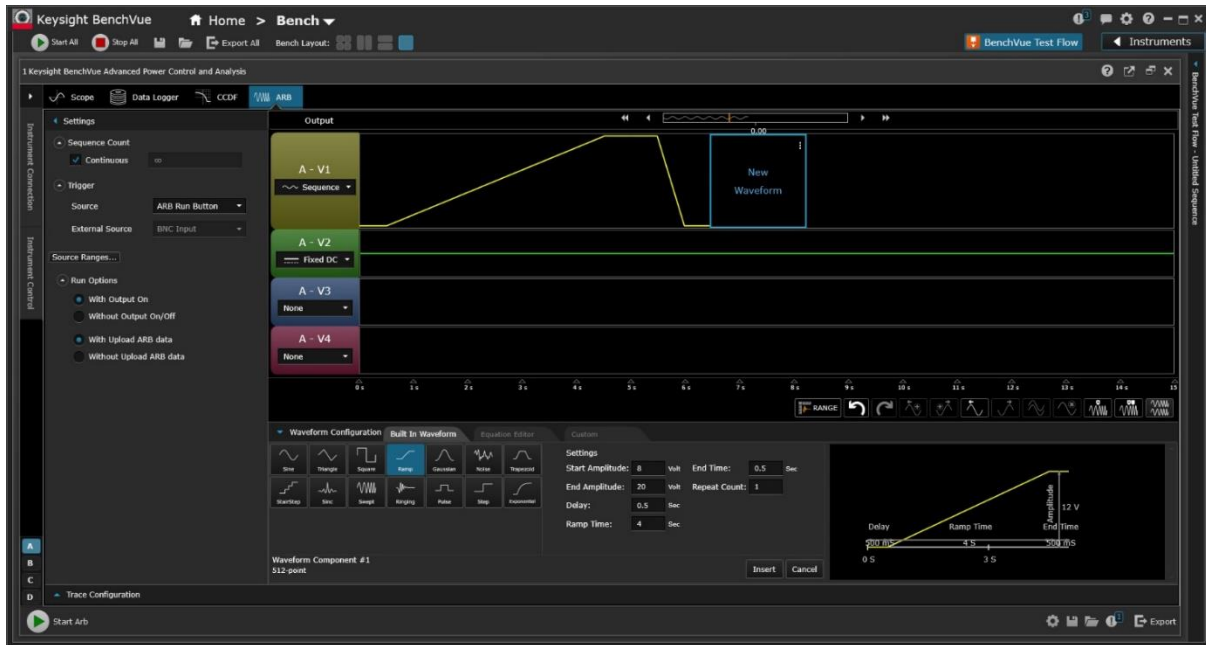

Figure 8.06 – The Advanced Power Control and Analysis Software’s arbitrary waveform generation feature.

It also supports the scope, data logger and cumulative current distribution function (CCDF) similar to the 14585A software. The following figure shows a screenshot of the scope function.

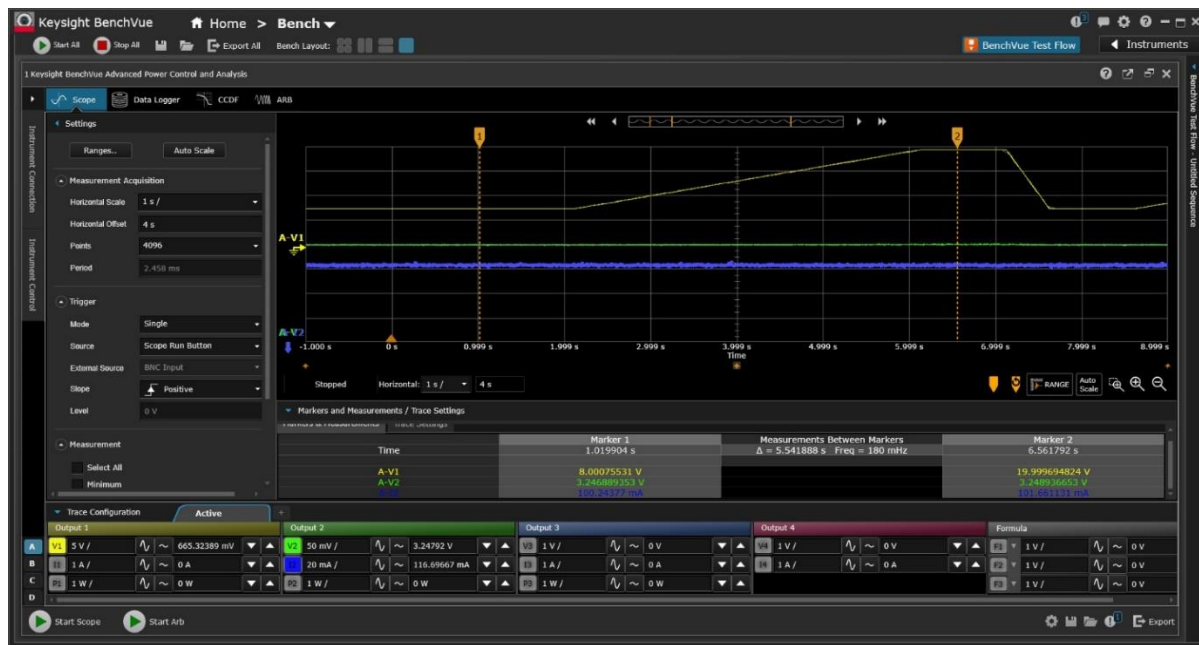

Figure 8.07 – The Advanced Power Control and Analysis Software’s scope feature.

## Power Supply Software

The Power Supply Software application in BenchVue can control a large number (~160) different power supplies and SMUs, including the B2900 series, the E3600 series, the N6900 and N7900 series of advanced power supplies and the RP7900 series of regenerative power supplies. Please refer to our online information for the most up-to-date list. The power supply software offers many benefits, which the list below summarizes.

- Easily track and record your power supply outputs to understand the impact of events to power draw
- Rapidly build custom test procedures or sequences with Test Flow to characterize your device in various conditions
- Quickly export data to popular tools, such as MATLAB and Microsoft Excel or Word for further analysis
- Conveniently access and control tests on your power supply remotely with the BenchVue Mobile App and monitor or respond to long-running tests from anywhere
- Deeper instrument controls with Command Expert integration
- KeysightCare software support subscription included

A very nice feature of the power supply software is that you can use BenchVue's built-in test sequencing capability to automate tests on your power supplies without having to do any programming. It supports all necessary operations such as conditional branching, looping, variables, math functions, string operations, etc. as shown in the following screen capture.

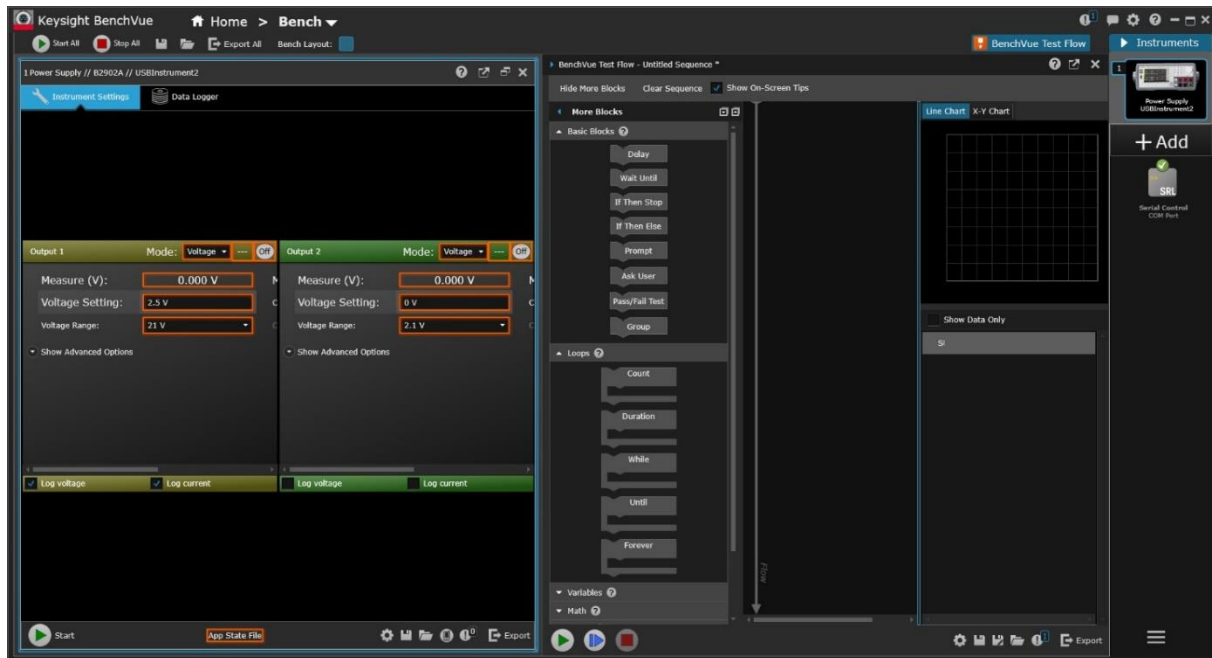

Figure 8.08 – The power supply software test sequencing utility allows you to automate test flows without having to do any programming.

The following screen capture shows the implementation and measurement results of a diode spot measurement performed using the power supply software.

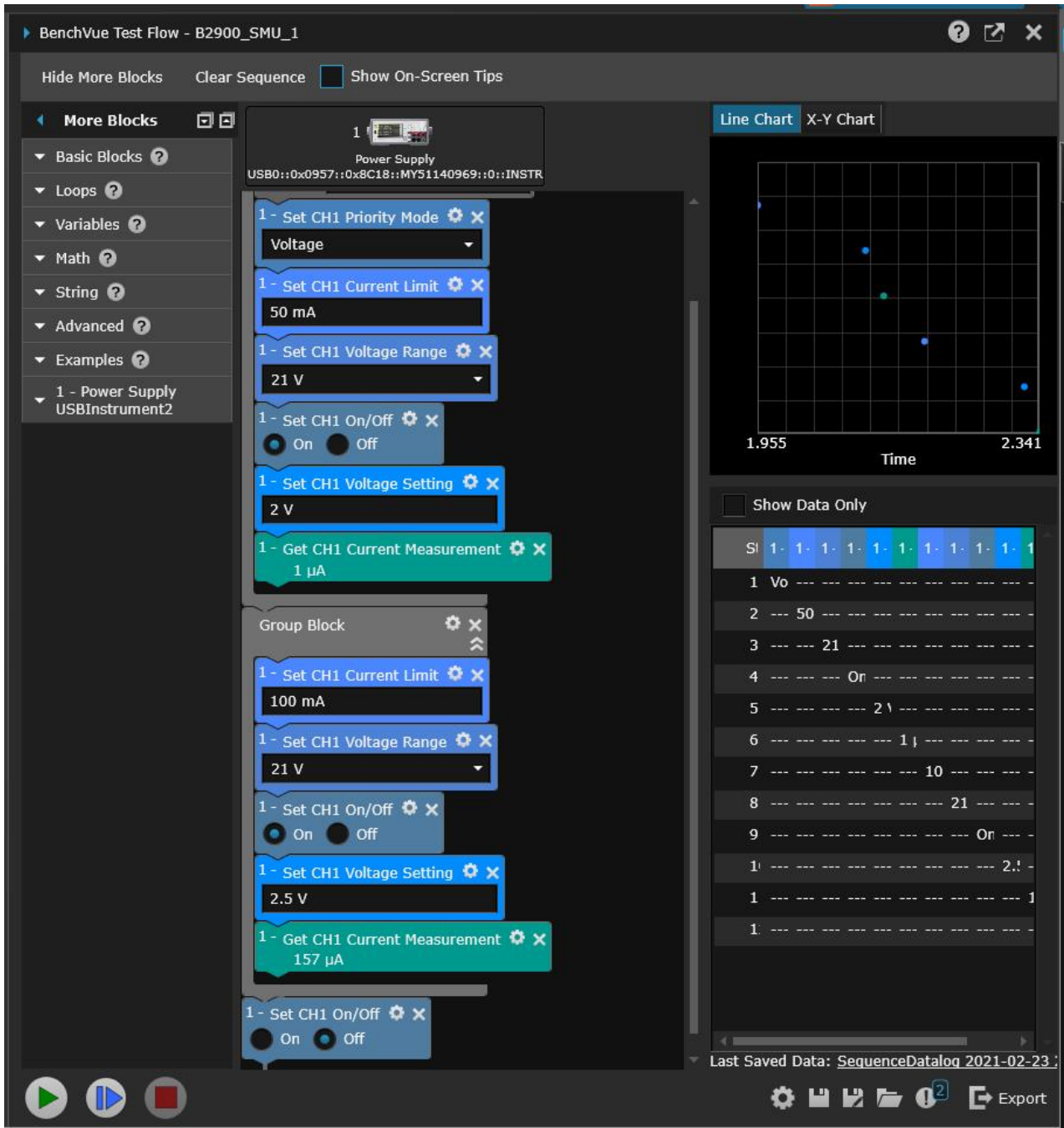

Figure 8.09 – Power supply software example showing a measurement sequence using a B2902A SMU.

## Glossary – Power Supply & Instrument Control Terminology

**Accuracy** – The degree of conformity of a measured or calculated quantity to its actual (true) value.

**ADE (application development environment)** — An integrated suite of software development programs. ADEs may include a text editor, compiler, and debugger, as well as other tools used in creating, maintaining, and debugging application programs. Example: Microsoft Visual Studio.

**ALWG** – The abbreviation of Arbitrary Linear Waveform Generation. ALWG is a waveform generation technique that synthesizes a waveform from a concatenated set of user-defined line segments.

**Ambient Temperature** – The temperature of the air immediately surrounding the power supply.

**API (application programming interface)** — An API is a well-defined set of software routines through which application program can access the functions and services provided by an underlying operating system or library. Example: IVI Drivers

**Apparent Power** – Apparent power is the sum of real and reactive power. It has units of Volt-Amps (VA).

**Auto-ranging Power Supply** – A power supply where the output characteristic between its maximum voltage and current points is determined by the its maximum output power, which is less than the product of its maximum voltage and current. This is in contrast to a rectangular power supply, where the product of its maximum current and voltage is equal to its maximum power (see Chapter 3).

**C#** — (Pronounced “C Sharp”) Newer C-like, component-oriented language that eliminates much of the difficulty associated with C/C++.

**Carryover Time** – The period of time that a power supply's output will remain within specifications after loss of AC input power. Sometimes the term used for this is holding time.

**Common Mode Noise** – The deviation that appears on both the positive and negative output terminals of the power supply with respect to ground. Its unit of measure is amperes since the current flowing from an output terminal to ground is an easily measurable parameter.

**Common Mode Rejection Ratio (CMRR)** – The ability of a circuit to reject input signals common to both input leads. The units of CMRR are positive decibels, defined as 20 times the log in base 10 of the ratio of the differential gain divided by the common-mode gain.

**Common Mode Voltage** – The voltage difference between the internal reference of an instrument and true earth ground.

**Complementary Tracking** – A director-follower interconnection similar to Auto-Tracking except that it only uses two supplies and the output voltage of the follower is always of opposite polarity with respect to the director. The amplitude of the follower's output voltage is equal to, or proportional to, that of the director. Often a pair of complementary tracking supplies are present in a single unit.

**Compliance Voltage** – The output voltage rating of a power supply operating in the constant current mode (analogous to the output current rating of a supply operating in the constant voltage mode).



**Constant Current Power Supply** – A regulated power supply that acts to maintain its output current constant in spite of changes in load, line, temperature, etc. Thus, for a change in load resistance, the output current remains constant while the output voltage changes by whatever amount necessary to accomplish this.

**Constant Voltage Power Supply** – A regulated power supply that acts to maintain its output voltage constant in spite of changes in load, line, temperature, etc. Thus, for a change in load resistance, the output voltage of this type of supply remains constant while the output current changes by whatever amount necessary to accomplish this.

**Constant Voltage/Constant Current (CV/CC) Power Supply** – A power supply that acts as a constant voltage source for comparatively large values of load resistance and as a constant current source for comparatively small values of load resistance. The automatic crossover or transition between these two modes of operation occurs at a "critical" or "crossover" value of load resistance  $R_c = E_s/I_s$ , where  $E_s$  is the front panel voltage control setting and  $I_s$  is the front panel current control setting.

**Constant Voltage/Current Limiting (CV/CL) Power Supply** – A supply similar to a CV/CC supply except for less precise regulation at low values of load resistance, i.e., in the current limiting region of operation.

**Crowbar Circuit** – An overvoltage protection circuit that monitors the output voltage of the supply and rapidly places a short circuit (or crowbar) across the output terminals if it exceeds a preset voltage level.

**Current Foldback** – Another form of current limiting often used in fixed output voltage supplies. For load resistance smaller than the crossover value, the current, as well as the voltage, decreases along a foldback locus.

**Direct I/O** — commands sent directly to an instrument, without the benefit of, or interference from a driver. SCPI Example: `SENSe:VOLTage:RANGe:AUTO`

**Drift** – The maximum change in power supply output during a stated period of time (usually 8 hours) following a warm-up period, with all influence and control quantities (such as: load, AC line, and ambient temperature) maintained constant. Drift includes periodic and random deviations (PARD) over a bandwidth from DC to 20Hz. (At frequencies above 20Hz, PARD has a separate specification.)

**DUT** – The abbreviation of Device Under Test. DUT is a very general term that can apply to simple components such as resistors, capacitors and transistors, but can also apply to more complex devices up to and including entire integrated circuits (ICs).

**Driver (or device driver)** — A collection of functions resident on a computer and used to control a peripheral device.

**DLL (dynamic link library)** — An executable program or data file bound to an application program and loaded only when needed, thereby reducing memory requirements. Several applications can simultaneously share the functions or data in a DLL.

**Efficiency** – Expressed in percent, efficiency is the total output power of the supply divided by the active input power. Unless otherwise specified, Keysight measures efficiency at maximum rated output power and at worst case conditions of the AC line voltage.

**Electromagnetic Interference (EMI)** – Any type of electromagnetic energy that could degrade the performance of electrical or electronic equipment. The EMI generated by a power supply can propagate either by conduction (via the input and output leads) or by radiation from the units' case. Some people use the terms "noise" and "radio-frequency interference" (RFI) in the same context.

**Inrush Current** – The maximum instantaneous value of the input current to a power supply when you first apply AC power.

**Ground Loop** – An undesirable measurement condition in which two or more conductive planes or surfaces connect to ground through multiple points, thereby allowing current to flow between them due to common mode voltage differences.

**Input/Output (I/O) layer** — The software that collects data from and issues commands to peripheral devices. The VISA function library is an example of an I/O layer that allows application programs and drivers to access peripheral instrumentation.

**IVI (Interchangeable Virtual Instruments)** — a standard instrument driver model defined by the IVI Foundation that enables engineers to exchange instruments made by different manufacturers without rewriting their code. [www.ivifoundation.org](http://www.ivifoundation.org).

**IVI COM drivers (also known as IVI Component drivers)** — IVI COM presents the IVI driver as a COM object in Visual Basic. You get all the intelligence and all the benefits of the development environment because IVI COM does things in a smart way and presents an easier, more consistent way to send commands to an instrument. It is similar across multiple instruments.

**Linear Power Supply** – An AC to DC power supply that employs a large transformer to convert the AC voltage down to a lower amplitude, followed by a series of rectifier and filtering circuits that produce a very clean ripple-free DC voltage. Linear power supplies have the disadvantages of typically being much larger and heavier than equivalent switching power supplies.

**Load Effect (Load Regulation)** – Load effect (or load regulation) is the change in the steady-state value of the DC output voltage or current resulting from a specified change in the load current (of a constant-voltage supply) or the load voltage (of a constant-current supply), with all other influence quantities maintained constant.

**Load Effect Transient Recovery Time** – Sometimes referred to as transient recovery time or transient response time, it is, loosely speaking, the time required for the output voltage of a power supply to return to within a level approximating the normal DC output following a sudden change in load current. More exactly, Load Transient Recovery Time for a CV supply is the time "X" required for the output voltage to recover to, and stay within "Y" millivolts of the nominal output voltage following a "Z" amp step change in load current --where:

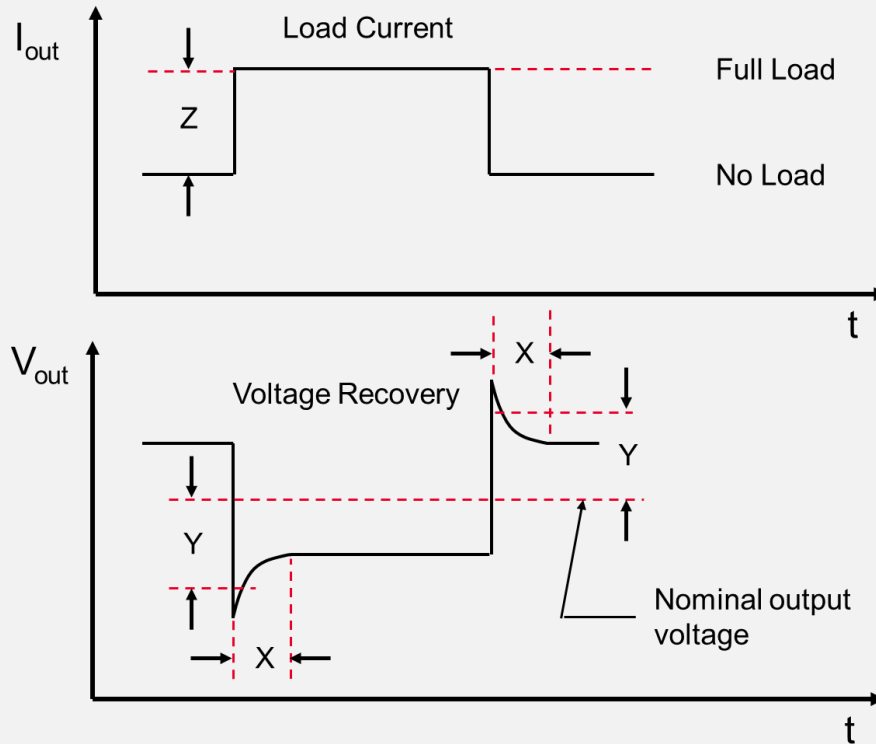

- (1) The value of "Y" has different specifications for each model but is generally of the same order as the load regulation specification.
- (2) We define the nominal output voltage as the DC level halfway between the steady state output voltage before and after the imposed load change.
- (3) "Z" is the specified load current change, typically equal to the full load current rating of the supply.

**Measurement Accuracy/Readback Accuracy** – For power supplies with self-measurement capabilities, the measurement accuracy is the maximum expected measurement error. Similar to programming accuracy, you can define the specification as a percentage of full scale or as a percentage and an offset.

**Microsoft COM (Component Object Model)** — The concept of software components is analogous to that of hardware components: as long as components present the same interface and perform the same functions, they are interchangeable. Software components are the natural extension of DLLs. Microsoft developed the COM standard to allow software manufacturers to create new software components that can work with an existing application program, without requiring that the programmer rebuild the application. It is this capability that allows programmers to interchange T&M instruments and their COM-based IVI-Component drivers.

**.NET Framework** — The .NET Framework is an object-oriented API that simplifies application development in a Windows environment. The .NET Framework has two main components: the common language runtime and the .NET Framework class library.

**Normal Mode Noise** – Normal mode noise is the voltage deviation on the positive output terminal with respect to the negative output terminal.

**Off-Line Power Supply** – A power supply whose input rectifier circuits operate directly from the AC power line, without transformer isolation.

**Output Impedance of a Power Supply** – At any frequency of load change,  $\Delta V_{out}/\Delta I_{out}$ . Strictly speaking, the definition applies only for a sinusoidal load disturbance, unless you make the measurement at zero frequency (DC). The output impedance of an ideal constant voltage power supply would be zero at all frequencies, while the output impedance for an ideal constant current power supply would be infinite at all frequencies.

**Output Noise** – Output noise is the deviation of the DC output voltage from its average value over a specified bandwidth. Datasheets typically express it as a peak-to-peak (p-p) value or as a root-mean-square (RMS) value.

**Periodic and Random Deviation (PARD)** – The term PARD is an acronym for "Periodic and Random deviation" and replaces the former term ripple and noise. PARD is the residual AC component that gets superimposed on the DC output voltage or current of a power supply. You measure PARD over a specified bandwidth, with all influence and control quantities maintained constant. The specifications for PARD are rms and/or peak-to-peak values over a bandwidth of 20Hz to 20MHz. Datasheets assign fluctuations below 20Hz to drift. Attempting to measure PARD with an instrument that has insufficient bandwidth may conceal high frequency spikes that could be detrimental to a load.

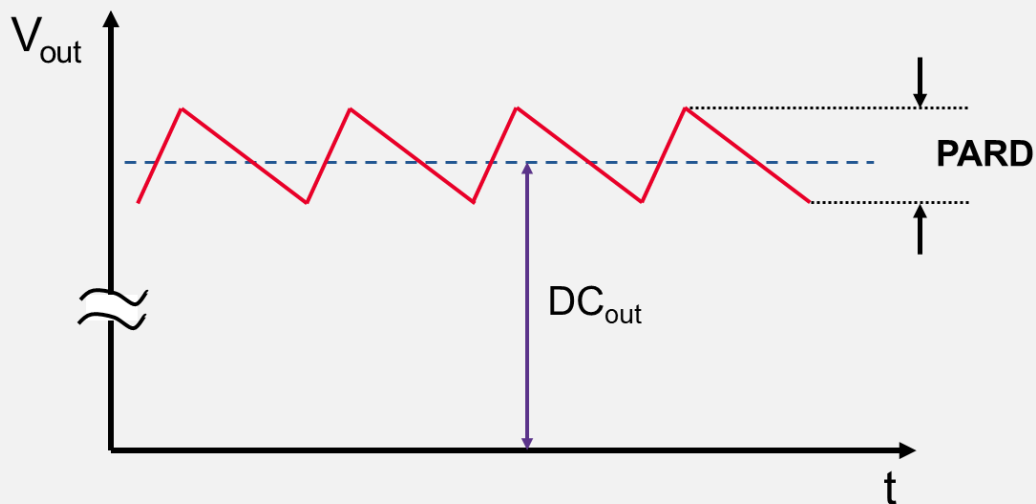

Output of DC power supply with superimposed PARD component.

**Plug and Play drivers** — (also known as universal instrument drivers) are an important category of proprietary drivers. Developers originally created the Plug and Play driver standards for VXI instruments (known as VXIplug&play standards). When these standards were adapted for non-VXI instruments they

became known simply as “Plug and Play” drivers. Library functions are in accessible C-language source and you can call them from programs written in VEE, BASIC, LabVIEW or LabWindows/CVI.

**Power Factor** – For an AC power system, the power factor is the ratio of the real power absorbed by a load to the apparent power flowing into that circuit.

**Programming Accuracy** – The maximum expected deviation of the actual value at the power supply's output from its programmed value. Datasheets sometimes show this specification as a percentage of full-scale voltage (such as “0.1% of  $V_{max}$ ”) and sometimes show it as a percentage plus offset (such as “0.05% + 25 mV”).

**Programming Speed** – The maximum time required for the output voltage or current to change from an initial value to within a tolerance band of the newly programmed value following the onset of a step change in the programming input signal. Because the programming speed depends on the loading of the supply and on whether the output is moving to a higher or lower value, datasheets usually specify programming speed at no load and full load and in both the up and down directions.

**Python** – Python is an interpreted (i.e. non-compiled), object-oriented, high-level programming language with dynamic semantics. Python has gained in popularity in recent years as it is an open-source programming language. This means that its interpreter and standard library are available in source or binary form without charge for all major platforms. In addition, the Python syntax is relatively simple and easy to learn and it also supports modules and packages to facilitate program modularity.

**Reactive Power** – Reactive power represents the power that you need to supply to the reactive (capacitive and inductive) elements of a circuit in order to get that circuit to function. Its units are Volt-Amps reactive (VAr).

**Real Power** – Real power (also known as active or true power) is the power consumed by the resistive elements of a circuit. Its units are Watts (W).

**Rectangular Power Supply** – A power supply where the product of its maximum current and voltage is equal to its maximum power. This is in contrast to an auto-ranging power supply, where the output characteristic is determined by its maximum power output which is less than the product of its maximum voltage and current (see Chapter 3).

**Remote Sensing (Remote Error Sensing)** – A means whereby a constant voltage power supply monitors and regulates its output voltage directly at the load terminals (instead of the power supply output terminals). Two low current sensing leads supply a connection between the load terminals and special sensing terminals located on the power supply, permitting the power supply output voltage to compensate for IR drops in the load leads (up to a specified limit).

**Repeatability** – The degree to which repeated measurements or calculations show the same or similar results.

**Resolution** – The lowest resolvable quantity of data that an instrument can accurately measure.

**RMS Value** – For repetitive time-varying voltage/current waveforms, the RMS value is the equivalent DC value that would dissipate the same amount of power (heat). For sinusoidal waveforms, you can derive the RMS value by dividing the signal amplitude by the square root of two (hence the designation “root-mean-square”).

**SCPI (Standard Commands for Programmable Instrumentation)** — SCPI defines a standard set of commands to control programmable test and measurement devices in instrumentation systems. Learn more at [www.scpiconsortium.org](http://www.scpiconsortium.org). See “Direct I/O” for example.

**SICL** — Standard Instrument Control Library (SICL) is a library of I/O function calls primarily implemented and supported by Keysight. Some of these are core functions that are common across all physical interfaces (GPIB, RS-232, etc.), while others are specific to the interface. The SICL library provides very complete and flexible control of instruments. C and C++ allow you to make optimal use of SICL, but you can also use SICL with Visual Basic and other environments that have the ability to call arbitrary Windows DLLs. SICL provides complete access to GPIB, RS-232, LAN, VXI message-based, and VXI register-based products.

**Source Effect/Line Effect/Source Regulation** – Source effect is the change in the steady-state value of the DC output voltage (of a CV supply) or current (of a CC supply) due to a specified change in the source (AC line) voltage, with all other influence quantities maintained constant. Usually you measure the source effect after a "complete" change in the AC line voltage; from low line to high line or vice-versa.

**Source/Monitor Unit (SMU)** – Also sometimes designated as “Source/Measure Unit.” The SMU is a measurement module that can force voltage or current and simultaneously measure voltage and/or current. Although often thought of as a DC measurement unit, the SMU does have some time sampling and pulsing capability.

#### **Stability (See Drift)**

**Switching Power Supply** – An AC to DC power supply that uses a switching regulator to control high-power pass transistors that feed full rectified and filtered AC line voltage into a step-down transformer and additional rectifying and filtering circuits. While more complex in design, switching power supplies are more efficient, smaller and lighter than equivalent linear power supplies. Modern switching power supplies can provide low-noise DC output equivalent to that of linear power supplies.

**Temperature Coefficient** – For a power supply operated at constant load and constant AC input, the maximum steady-state change in output voltage (for a constant voltage supply) or output current (for a constant current supply) for each degree change in the ambient temperature, with all other influence quantities maintained constant.

**Transformer** – A transformer is an electronic component composed of two or more coils of wire wrapped around a ferro-electric material used to transfer electrical energy via an alternating magnetic field. They are key components in all power supplies.

**Warm Up Time** – The time interval required by a power supply to meet all performance specifications after you first turn it on.

**Universal drivers** — Another name for Plug and Play drivers

**VISA (Virtual Instrument Software Architecture)** — The VXIplug&play Foundation created the VISA standard. Drivers that conform to the VXIplug&play standards always perform I/O through the VISA library. Therefore, if you are using Plug and Play drivers, you will need the VISA I/O library. The original intent of the VISA standard was to provide a common set of function calls that are similar across physical interfaces. In practice, VISA libraries tend to be specific to the vendor’s interface.

**VISA-COM** — The VISA-COM library is a COM interface for I/O developed as a companion to the VISA specification. VISA-COM I/O provides the services of VISA in a COM-based API. VISA-COM includes some higher-level services that are not available in VISA, but in terms of low-level I/O communication capabilities, VISA-COM is a subset of VISA. Keysight IVI-Component drivers use Keysight VISA-COM and require the user to also install Keysight VISA.

**Work** – The action of a force on a particle as the particle moves over a distance. Although work is a scalar quantity, to compute work we have to know the various vector components of force acting on a particle as it moves through three-dimensional space.

## Appendix A – Overview of Keysight Power Solutions

The following product list is far from comprehensive, but it does provide an overview of Keysight's most popular power products. For a complete up-to-date list, please visit our website at [www.keysight.com](http://www.keysight.com).

### Basic Power Supplies

#### E36100 Series of Basic DC Power Supplies

Many bench power supplies lack good current readback, lack modern I/O capabilities and are difficult to cost-effectively automate. In contrast, the E36100 Series save space on your bench or in your ATE system and possess excellent current measurement accuracy and modern I/O capabilities. Key features of the E36100 Series include:

- Clean power, excellent regulation, fast transient response and USB and LAN (LXI Core) interfaces in a compact 2U x ¼ enclosure
- High accuracy, especially for low-range current readback (critical for characterizing low-power devices over wide ranges)
- High-contrast OLED display viewable from wide angles



Figure A.01 – The E36100 series of basic power supplies.

Typical applications for the E36100 series include:

- R&D staff doing prototype evaluation
- Design qualification engineers and technicians doing product, circuit and component qualification
- Test automation staff doing basic test set creation for low volume characterization, burn-in and production test



## E36300 Series of Triple Output Bench Supplies

In cases where you need multiple bench power supplies in a small form factor, Keysight's E36300 series of triple output DC power supplies provide the perfect balance of flexibility, size and convenience.

- Low output noise — ripple and noise < 350  $\mu$ Vrms
- Accurate programming and readback accuracy < 0.04%
- Excellent stability with line and load regulation at 0.01%
- All three outputs are isolated and operate independently
- 4-wire sense to improve measurement accuracy
- Overvoltage, and overcurrent device protection
- Connectivity: USB, LAN (LXI Core), GPIB (optional)



Figure A.02 – The E36300 series of triple output DC power supplies.

Typical applications for the E36300 series are similar to those of the E36100 series.

## N8900 Series of 5, 10 and 15 kW Auto-Ranging DC Supplies

Rectangular power supplies can only output maximum power when operating at their maximum current and voltage values (see Chapter 3). In contrast, auto-ranging power supplies can source maximum power along the range of voltages and currents that span their constant power curve, which provides tremendous flexibility. For example, the Keysight N8932A and N8952A 15 kW power supplies can output any voltage from 0 to 200 V and any current from 0 to 210 A as long as the product of the voltage and current does not exceed 15,000 Watts. In addition to this versatility, the N8900 series have many useful attributes including:

- The ability to source up to 1500 V and up to 510 A
- The capability to gang up to 12 units together in primary/secondary configuration
- Over voltage, over current and over temperature protection features
- High power density (only 3 U tall)
- Support for LAN (LXI Core), USB, GPIB, and analog standard communication protocols



Figure A.03 – The N8900 series of 5 kW, 10 kW and 15 kW auto-ranging DC power supplies.

Typical applications for the N8900 series include:

- Automotive, Industrial and Transportation
  - Motors, Motor Controllers and Drivetrains
  - Electric vehicles – Inverters driving AC traction motors
  - Electric vehicle battery charge/discharge testing
- Energy Conversion
  - Power conditioners and uninterruptable power supplies with inverters
  - Inverters in wind turbine and photovoltaic solar generation
  - Battery test (charge/discharge systems)
- High Current
  - Large router and Datacom switch systems
  - High-current IGBT and Power MOSFET applications (components and products using these components)

## Advanced Power Supplies

### N6900/N7900 Advanced Power System DC Supplies

You can divide power supplies into basic power supplies and system power supplies (which have more capabilities). However, many practical applications involving system power supplies often require the use of additional equipment such as e-Loads, switches and measurement hardware (such as shunts, DMMs, and digitizers). Not only are these types of solutions difficult to design, deploy, and maintain, but they often create compromises in performance and test accuracy.

An advanced power supply (APS) resolves these issues by integrated all of the above needs into a single instrument. An APS has faster output and transition speeds than traditional power supplies, and an APS also improves throughput due to its fast command processing speed and smart triggering features. In addition, an APS can easily capture a DUT's current profile since it possesses voltage and current digitizers that provide scope-like capabilities (with better resolution) and DMM-like measurement accuracy. Keysight's patented seamless current measurement ranging feature of course also provides more accurate measurement results. Finally, other capabilities that include two-quadrant operation, DUT protection features, arbitrary waveform generation, output sequencing and "black box" recording eliminate the need for most additional measurement instrumentation.



Figure A.04 – The N6900 and N7900 series of advanced power supplies solve the limitations of basic and system power supplies.

Typical applications include:

- Bi-Directional Power
  - Battery conditioning and test, Super Cap test
  - Battery simulation
  - Electromechanical systems with regenerative energy
  - Devices with bi-directional power flow thru device
- Avionics & Automotive Electronics
  - Simulate real-world DC with transients and interrupts
  - Test systems to industry and government standards
- Semiconductor Test
  - High-current, low-voltage ASICs and FPGAs
  - Transient load response, dynamic current measurement, low noise, sequencing multiple supplies

## RP7900 Series of Regenerative Power Systems

The Keysight RP7900 Series regenerative power supply provides both sourcing and electrical loading up to 20 kW. A bidirectional supply is ideal for testing energy storage and converters. Most electronic loads convert energy to heat which can cause a temperature rise in a rack — leading to measurement errors. A regenerative power supply safely returns the energy to the grid eliminating additional costs to remove the excess heat.



Figure A.05 – The RP7900 regenerative power system returns sunk power to the AC line, thereby saving power and reducing dissipated heat.

Some of the key RP7900 features include:

- Operate in a two-quadrant mode as a power source and regenerative electronic load
- Up to 2000 V, up to  $\pm 800$  A, up to 20 kW per instrument
- Fast output speed and sub-millisecond command processing time
- Create up to 200 kW power or loading through easy parallel connection
- 2-to-1 output autoranging for greater flexibility
- Regeneration returns 90% of power to the grid, reducing cooling costs
- RP7970 Series offers photovoltaic simulation capability
- Connectivity includes LAN (LXI Core), USB, and GPIB

## Electronic Loads

### N3300 Series Modular DC Electronic Load

The N3300 Series of DC electronic loads supports up to six channels, each with a unique maximum voltage and current. They allow the design of a flexible automated test equipment (ATE) system to verify many types of power supplies, DC-to-DC converters, and batteries. Add additional modules to test multiple power sources simultaneously. Each module includes a 16-bit voltage, current, and power measurement system.

- Choice of half-rack width or full-rack width mainframe
- Constant current, constant voltage, and constant resistance modes
- Built-in transient generator
- 16-bit voltage and current measurements captured simultaneously
- Stable operation down to 0 V
- Modular design for system flexibility
- Fast command processing and settling times
- Available interfaces: analog, RS232, and GPIB



Figure A.06 – The N3300 series of modular DC electronic loads.

Electronic loads have many applications some of which include:

- DC to DC converter test
- Battery test

## Benchtop Power Analysis

### N6705C DC Power Analyzer

The N6705C DC Power Analyzer provides unrivaled productivity gains for sourcing and measuring DC voltage and current into your DUT by integrating up to 4 advanced power supplies with DMM, Scope, Arb, and Data Logger features. The N6705C eliminates the need to gather multiple pieces of equipment and create complex test setups including transducers (such as current probes and shunts) to measure current into your DUT. The DC Power Analyzer also eliminates the need to develop and debug programs to control a collection of instruments and take useful measurements because all functions and measurements are available at the front panel. If you need increased functionality, you can use the DC Power Analyzer with either PathWave BenchVue BV9200 Control and Analysis Software or 14585A Control and Analysis Software. If you need automated bench setups, then the N6705C is fully programmable over GPIB, USB and LAN (LXI Compliant). A list shown below summarizes the N6705C's features.

- 4-slot mainframe holds up to 600 W of total power and up to 4 modules. More than 30 DC power modules to choose from (modules ordered separately)
- Voltmeter accuracy: Up to 0.025% + 50  $\mu$ V, up to 18 bits
- Ammeter accuracy: Up to 0.025% + 8 nA, up to 18 bits
- Arbitrary waveform generator function: Bandwidth up to 100 kHz, output power up to 500 W
- Scope function: Digitizes voltage and current at up to 200 kHz, 512 kpts, up to 18 bits
- Data logger function: Measurement interval from 20  $\mu$ s to 60 s, max of 500 M readings per datalog
- 4 GB of non-volatile data storage for data log, scope traces, instrument settings



Figure A.07 – The N6705A mainframe permits fast and easy benchtop testing using a variety of supported modules.

If you have N6705C tests that you want to automate, then the N6700 Series of mainframes provides the perfect solution. Each mainframe can support up to four outputs, and its 1 U height makes it ideal for rack mounting. Key features of the N6700 Series include:

- Choose from 400, 600, or 1200 W mainframe
- Modular solution with 1U low-profile
- Up to four outputs per mainframe
- Mix and match module power and performance levels
- Choose modules from three levels of performance
- Sink current with DC electronic load modules
- Fast command processing and settling times
- Interfaces available — LAN (LXI Core), USB, GPIB



Figure A.08 – The N6700C, N6701C and N6702C mainframes have a 1 U profile and support the same modules as the N6705C, making them ideal for automated test.

## AC Power Sourcing and Analysis

### AC Sources

In cases where you need to convert AC line voltage to a different AC voltage you need to use an AC power source. Keysight offers two families of AC power sources. The AC6800B series of basic AC sources provide stable, reliable power with models available up to 4000 VA. The 6800C series of performance AC sources provide a complete AC test solution with built in arbitrary waveform generator to simulate many types of power waveforms, at power levels up to 1750 VA. Both families can also produce DC power, either alone or as a DC offset to an AC waveform.



Figure A.09 – Keysight’s family of AC power sources.

Key benefits of these products include:

- Achieve more stable and reliable basic AC power measurements up to 4000 VA
- Easy operation with an intuitive user interface
- Access and control the power source remotely via LAN/LXI Core, USB or optional GPIB
- Lower your cost of ownership with global support & longest standard warranty in the industry

### PA2200 IntegraVision Power Analyzers

Keysight’s PA2201A and PA2203A IntegraVision power analyzers provide you with a single instrument that gives you the dynamic views you need to see, measure and prove the performance of your AC & DC designs. The PA2201A supports 2-channels and 1-phase power analysis; the PA2203A supports 4-channels and 3-phase power analysis. These products provide high accuracy and high resolution data and support up to 50 A of direct current measurement. They support single-shot measurements at a sampling rate of 5 Mega-samples per second with 16-bit resolution, enabling you to see inrush and transient currents. They are also easy-to-use with a large touch screen user interface that allows you to visualize waveforms in real time.



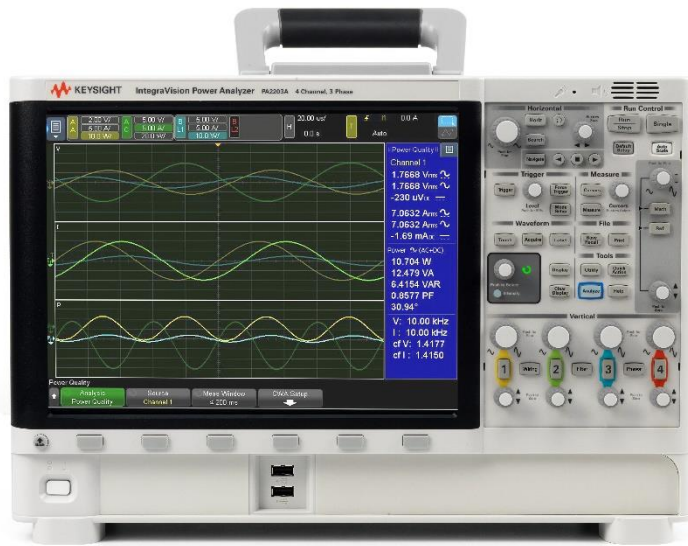

Figure A.10 – Keysight’s PA2201A and PA2203A power analyzers simplify the evaluation of one and three phase power systems.

These instruments’ key capabilities include:

- Simultaneous measurement of every waveform at 5 MSa/s with 16 bit resolution
- A wide time base, with a maximum setting of 50 s/div (500 seconds) and a minimum setting of 20  $\mu$ s/div (200  $\mu$ s)
- Voltage measurement up to 1000  $V_{RMS}$  / 2000  $V_{peak}$  with BW up to 2.5 MHz
- Direct current: measures using 2 internal shunts (2 Arms and 50 Arms) with BW up to 100 kHz
- Support for external current probes and transducers of up to 10 V full scale with BW up to 2.5 MHz
- Built-in voltage and current measurement capability of waveform characteristics, including DC,  $AC_{RMS}$ ,  $AC_{RMS}$  with DC, Frequency, Maximum, Minimum and Crest Factor
- Measurement and display of power parameters: Real Power, Apparent Power, Reactive Power, Phase Angle and Power Factor
- Other capabilities include Voltage/Current harmonic measurement up to 250 orders, Efficiency, Amp-Hours, Watt-Hours, VA-Hours

Common applications of the PA2201A and PA2203A power analyzers include test and design of electronic power conversion systems such as:

- Inverters/converters: AC to DC, DC to DC, DC to AC, solar inverters
- Uninterruptable power supplies, battery chargers, battery systems, battery management systems
- Auto / electric / hybrid vehicle, rail, aircraft, satellite power systems
- Lighting systems and electronic ballasts
- Appliance

Learn more at: [www.keysight.com](http://www.keysight.com)

For more information on Keysight Technologies' products, applications or services, please contact your local Keysight office. The complete list is available at: [www.keysight.com/find/contactus](http://www.keysight.com/find/contactus)

